

Hypertherm[®]

Duramax™ Retrofit Torch

***HRT₂ and MRT₂ for
powermax600[®], powermax800[®],
powermax900[®], MAX42[®], and MAX43[®]***



Operator Manual – 807530

Revision 1

Duramax™ Retrofit Torch
HRT₂ and MRT₂ for
powermax600® , powermax800® ,
powermax900® , MAX42® , and MAX43®

Operator Manual

(P/N 807530)

Revision 1 – May 2012

Hypertherm, Inc.
Hanover, NH USA
www.hypertherm.com
email: info@hypertherm.com

© 2012 Hypertherm, Inc.
All Rights Reserved

Hypertherm, Powermax, and Duramax are trademarks of Hypertherm, Inc.
and may be registered in the United States and/or other countries.

Hypertherm, Inc.

Etna Road, P.O. Box 5010
Hanover, NH 03755 USA
603-643-3441 Tel (Main Office)
603-643-5352 Fax (All Departments)
info@hypertherm.com (Main Office Email)
800-643-9878 Tel (Technical Service)
technical.service@hypertherm.com (Technical Service Email)
800-737-2978 Tel (Customer Service)
customer.service@hypertherm.com (Customer Service Email)
866-643-7711 Tel (Return Materials Authorization)
877-371-2876 Fax (Return Materials Authorization)
return.materials@hypertherm.com (RMA email)

Hypertherm Automation

5 Technology Drive, Suite 300
West Lebanon, NH 03784 USA
603-298-7970 Tel
603-298-7977 Fax

Hypertherm Plasmatechnik GmbH

Technologiepark Hanau
Rodenbacher Chaussee 6
D-63457 Hanau-Wolfgang, Deutschland
49 6181 58 2100 Tel
49 6181 58 2134 Fax
49 6181 58 2123 (Technical Service)

Hypertherm (S) Pte Ltd.

82 Genting Lane
Media Centre
Annexe Block #A01-01
Singapore 349567, Republic of Singapore
65 6841 2489 Tel
65 6841 2490 Fax
65 6841 2489 (Technical Service)

Hypertherm (Shanghai) Trading Co., Ltd.

Unit A, 5th Floor, Careri Building
432 West Huai Hai Road
Shanghai, 200052
PR China
86-21 5258 3330/1 Tel
86-21 5258 3332 Fax

Hypertherm Europe B.V.

Vaartveld 9
4704 SE
Roosendaal, Nederland
31 165 596907 Tel
31 165 596901 Fax
31 165 596908 Tel (Marketing)
31 165 596900 Tel (Technical Service)
00 800 4973 7843 Tel (Technical Service)

Hypertherm Japan Ltd.

Level 9, Edobori Center Building
2-1-1 Edobori, Nishi-ku
Osaka 550-0002 Japan
81 6 6225 1183 Tel
81 6 6225 1184 Fax

Hypertherm Brasil Ltda.

Rua Bras Cubas, 231 – Jardim Maia
Guarulhos, SP - Brasil
CEP 07115-030
55 11 2409 2636 Tel
55 11 2408 0462 Fax

Hypertherm México, S.A. de C.V.

Avenida Toluca No. 444, Anexo 1,
Colonia Olivar de los Padres
Delegación Álvaro Obregón
México, D.F. C.P. 01780
52 55 5681 8109 Tel
52 55 5683 2127 Fax

Hypertherm Korea Branch

#3904 Centum Leaders Mark B/D,
1514 Woo-dong, Haeundae-gu, Busan
Korea, 612-889
82 51 747 0358 Tel
82 51 701 0358 Fax

ELECTROMAGNETIC COMPATIBILITY (EMC)

Introduction

Hypertherm's CE-marked equipment is built in compliance with standard EN60974-10. The equipment should be installed and used in accordance with the information below to achieve electromagnetic compatibility.

The limits required by EN60974-10 may not be adequate to completely eliminate interference when the affected equipment is in close proximity or has a high degree of sensitivity. In such cases it may be necessary to use other measures to further reduce interference.

This cutting equipment is designed for use only in an industrial environment.

Installation and use

The user is responsible for installing and using the plasma equipment according to the manufacturer's instructions.

If electromagnetic disturbances are detected then it shall be the responsibility of the user to resolve the situation with the technical assistance of the manufacturer. In some cases this remedial action may be as simple as earthing the cutting circuit, see *Earthing of the work piece*. In other cases, it could involve constructing an electromagnetic screen enclosing the power source and the work complete with associated input filters. In all cases, electromagnetic disturbances must be reduced to the point where they are no longer troublesome.

Assessment of area

Before installing the equipment, the user shall make an assessment of potential electromagnetic problems in the surrounding area. The following shall be taken into account:

- a. Other supply cables, control cables, signaling and telephone cables; above, below and adjacent to the cutting equipment.
- b. Radio and television transmitters and receivers.
- c. Computer and other control equipment.
- d. Safety critical equipment, for example guarding of industrial equipment.
- e. Health of the people around, for example the use of pacemakers and hearing aids.
- f. Equipment used for calibration or measurement.
- g. Immunity of other equipment in the environment. User shall ensure that other equipment being used in the environment is compatible. This may require additional protection measures.
- h. Time of day that cutting or other activities are to be carried out.

The size of the surrounding area to be considered will depend on the structure of the building and other activities that are taking place. The surrounding area may extend beyond the boundaries of the premises.

Methods of reducing emissions

Mains supply

Cutting equipment must be connected to the mains supply according to the manufacturer's recommendations. If interference occurs, it may be necessary to take additional precautions such as filtering of the mains supply.

Consideration should be given to shielding the supply cable of permanently installed cutting equipment, in metallic conduit or equivalent. Shielding should be electrically continuous throughout its length. The shielding should be connected to the cutting mains supply so that good electrical contact is maintained between the conduit and the cutting power source enclosure.

Maintenance of cutting equipment

The cutting equipment must be routinely maintained according to the manufacturer's recommendations. All access and service doors and covers should be closed and properly fastened when the cutting equipment is in operation. The cutting equipment should not be modified in any way, except as set forth in and in accordance with the manufacturer's written instructions. For example, the spark gaps of arc striking and stabilizing devices should be adjusted and maintained according to the manufacturer's recommendations.

Cutting cables

The cutting cables should be kept as short as possible and should be positioned close together, running at or close to the floor level.

Equipotential bonding

Bonding of all metallic components in the cutting installation and adjacent to it should be considered.

However, metallic components bonded to the workpiece will increase the risk that the operator could receive a shock by touching these metallic components and the electrode (nozzle for laser heads) at the same time.

The operator should be insulated from all such bonded metallic components.

Earthing of the workpiece

Where the workpiece is not bonded to earth for electrical safety, nor connected to earth because of its size and position, for example, ship's hull or building steel work, a connection bonding the workpiece to earth may reduce emissions in some, but not all instances. Care should be taken to prevent the earthing of the workpiece increasing the risk of injury to users, or damage to other electrical equipment. Where necessary, the connection of the workpiece to earth should be made by a direct connection to the workpiece, but in some countries where direct connection is not permitted, the bonding should be achieved by suitable capacitances selected according to national regulations.

Note: The cutting circuit may or may not be earthed for safety reasons. Changing the earthing arrangements should only be authorized by a person who is competent to assess whether the changes will increase the risk of injury, for example, by allowing parallel cutting current return paths which may damage the earth circuits of other equipment. Further guidance is provided in IEC 60974-9, Arc Welding Equipment, Part 9: Installation and Use.

Screening and shielding

Selective screening and shielding of other cables and equipment in the surrounding area may alleviate problems of interference. Screening of the entire plasma cutting installation may be considered for special applications.

Attention

Genuine Hypertherm parts are the factory-recommended replacement parts for your Hypertherm system. Any damage or injury caused by the use of other than genuine Hypertherm parts may not be covered by the Hypertherm warranty, and will constitute misuse of the Hypertherm Product.

You are solely responsible for the safe use of the Product. Hypertherm does not and cannot make any guarantee or warranty regarding the safe use of the product in your environment.

General

Hypertherm, Inc. warrants that its Products shall be free from defects in materials and workmanship for the specific periods of time set forth herein and as follows: if Hypertherm is notified of a defect (i) with respect to the power supply within a period of two (2) years from the date of its delivery to you, with the exception of Powermax brand power supplies, which shall be within a period of three (3) years from the date of delivery to you, and (ii) with respect to the torch and leads within a period of one (1) year from its date of delivery to you, and with respect to torch lifter assemblies within a period of one (1) year from its date of delivery to you, and with respect to laser heads within a period of one (1) year from its date of delivery to you, and with respect to Automation products one (1) year from its date of delivery to you, with the exception of the EDGE Pro and MicroEDGE Pro CNCs and ArcGlide THC, which shall be within a period of two (2) years from the date of delivery to you.

This warranty shall not apply to any Powermax brand power supplies that have been used with phase converters. In addition, Hypertherm does not warranty systems that have been damaged as a result of poor power quality, whether from phase converters or incoming line power. This warranty shall not apply to any Product which has been incorrectly installed, modified, or otherwise damaged.

Hypertherm provides repair, replacement or adjustment of the Product as the sole and exclusive remedy, if and only if the warranty set forth herein properly is invoked and applies. Hypertherm, at its sole option, shall repair, replace, or adjust, free of charge, any defective Products covered by this warranty which shall be returned with Hypertherm's prior authorization (which shall not be unreasonably withheld), properly packed, to Hypertherm's place of business in Hanover, New Hampshire, or to an authorized Hypertherm repair facility, all costs, insurance and freight pre paid by the customer. Hypertherm shall not be liable for any repairs, replacement, or adjustments of Products covered by this warranty, except those made pursuant to this paragraph and with Hypertherm's prior written consent.

The warranty set forth above is exclusive and is in lieu of all other warranties, express, implied, statutory, or otherwise with respect to the Products or as to the results which may be obtained therefrom, and all implied warranties or conditions of quality or of merchantability or fitness for a particular purpose or against infringement. The foregoing shall constitute the sole and exclusive remedy for any breach by Hypertherm of its warranty.

Distributors/OEMs may offer different or additional warranties, but Distributors/OEMs are not authorized to give any additional warranty protection to you or make any representation to you purporting to be binding upon Hypertherm.

Patent indemnity

Except only in cases of products not manufactured by Hypertherm or manufactured by a person other than Hypertherm not in strict conformity with Hypertherm's specifications and in cases of designs, processes, formulae, or combinations not developed or purported to be developed by Hypertherm, Hypertherm will have the right to defend or settle, at its own expense, any suit or proceeding brought against you alleging that the use of the Hypertherm product, alone and not in combination with any other product not supplied by Hypertherm, infringes any patent of any third party. You shall notify Hypertherm promptly upon learning of any action or threatened action in connection with any such alleged infringement (and in any event no longer than fourteen (14) days after learning of any action or threat of action), and Hypertherm's obligation to defend shall be conditioned upon Hypertherm's sole control of, and the indemnified party's cooperation and assistance in, the defense of the claim.

Limitation of liability

In no event shall Hypertherm be liable to any person or entity for any incidental, consequential direct, indirect, punitive or exemplary damages (including but not limited to lost profits) regardless of whether such liability is based on breach of contract, tort, strict liability, breach of warranty, failure of essential purpose, or otherwise, and even if advised of the possibility of such damages.

National and local codes

National and local codes governing plumbing and electrical installation shall take precedence over any instructions contained in this manual. In no event shall Hypertherm be liable for injury to persons or property damage by reason of any code violation or poor work practices.

Liability cap

In no event shall Hypertherm's liability, if any, whether such liability is based on breach of contract, tort, strict liability, breach of warranties, failure of essential purpose or otherwise, for any claim, action, suit or proceeding (whether in court, arbitration, regulatory proceeding or otherwise) arising out of or relating to the use of the Products exceed in the aggregate the amount paid for the Products that gave rise to such claim.

Insurance

At all times you will have and maintain insurance in such quantities and types, and with coverage sufficient and appropriate to defend and to hold Hypertherm harmless in the event of any cause of action arising from the use of the products.

Transfer of rights

You may transfer any remaining rights you may have hereunder only in connection with the sale of all or substantially all of your assets or capital stock to a successor in interest who agrees to be bound by all of the terms and conditions of this Warranty. Within thirty (30) days before any such transfer occurs, you agree to notify in writing Hypertherm, which reserves the right of approval. Should you fail timely to notify Hypertherm and seek its approval as set forth herein, the Warranty set forth herein shall be null and void and you will have no further recourse against Hypertherm under the Warranty or otherwise.

Safety information

Before operating any Hypertherm equipment, read the separate *Safety and Compliance Manual* (80669C) included with your product for important safety information.

ELECTROMAGNETIC COMPATIBILITY (EMC)	EMC-1
WARRANTY	W-1
Safety information	2
Section 1	
Specifications	1-1
Component weights.....	1-2
Duramax HRT ₂ hand torch dimensions	1-2
Duramax MRT ₂ full-length machine torch dimensions	1-2
Duramax MRT ₂ without positioning sleeve (mini torch).....	1-2
Section 2	
Torch Setup	2-1
Introduction	2-2
Consumable life.....	2-2
Hand torch setup	2-2
Choose the hand torch consumables	2-3
Install the hand torch consumables.....	2-4
Machine torch setup.....	2-5
Converting a Duramax retrofit machine torch into a mini torch	2-6
Mount the torch.....	2-8
Choose the machine torch consumables.....	2-10
Install the machine torch consumables	2-12
Aligning the torch	2-12
Torch installation	2-13
Torches with a quick disconnect connector.....	2-13
Torches without a quick disconnect connector - Powermax600 CE	2-14
ON/OFF Pendant connection	2-15
Section 3	
Operation	3-1
Using the cut charts	3-2
55 amp mechanized shielded consumables.....	3-3
50 amp mechanized shielded consumables.....	3-4
45 amp mechanized shielded consumables.....	3-5
40 amp mechanized shielded consumables.....	3-8
45 amp mechanized unshielded consumables	3-9
40 amp mechanized unshielded consumables	3-12
FineCut® consumables.....	3-13
Using the hand torch.....	3-17
Operate the safety trigger	3-17
Hand torch cutting hints	3-18
Start a cut from the edge of the workpiece.....	3-19
Pierce a workpiece.....	3-20
Gouge a workpiece	3-21
General guidelines for gouging.....	3-22

TABLE OF CONTENTS

Common hand-cutting faults	3-22
Using the machine torch	3-23
Ensure the torch and table are set up correctly	3-23
Understand and optimize cut quality.....	3-23
To pierce a workpiece using the machine torch	3-26
Common machine-cutting faults.....	3-26

Section 4

Maintenance and parts	4-1
Perform routine maintenance	4-2
Inspect the consumables	4-3
Hand torch replacement parts – Duramax HRT ₂	4-4
Machine torch replacement parts – Duramax MRT ₂	4-5
Accessory parts.....	4-6

Section 1

Specifications

In this section:

Component weights	1-2
Duramax HRT ₂ hand torch dimensions	1-2
Duramax MRT ₂ full-length machine torch dimensions	1-2
Duramax MRT ₂ without positioning sleeve (mini torch)	1-2

SPECIFICATIONS

Component weights

Torch type	Weight – kg (lbs)
Hand torch 7.6 m (25 ft)	3.2 (7.1)
Hand torch 15 m (50 ft)	5.7 (12.6)
Machine torch 7.6 m (25 ft)	3.4 (7.5)
Machine torch 15 m (50 ft)	5.9 (13.0)

Duramax HRT₂ hand torch dimensions

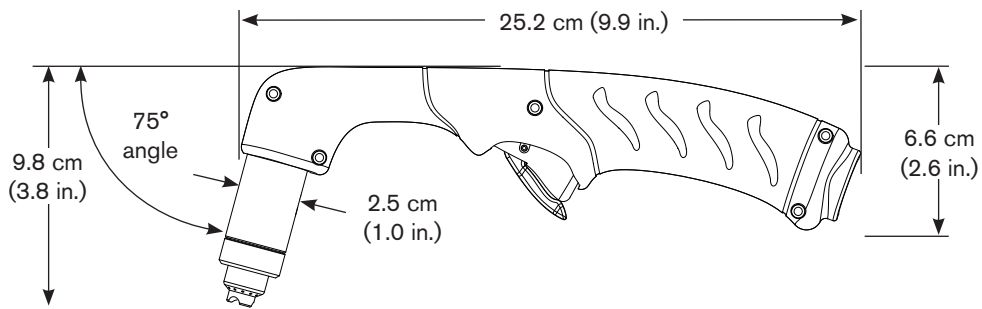

Duramax MRT₂ full-length machine torch dimensions

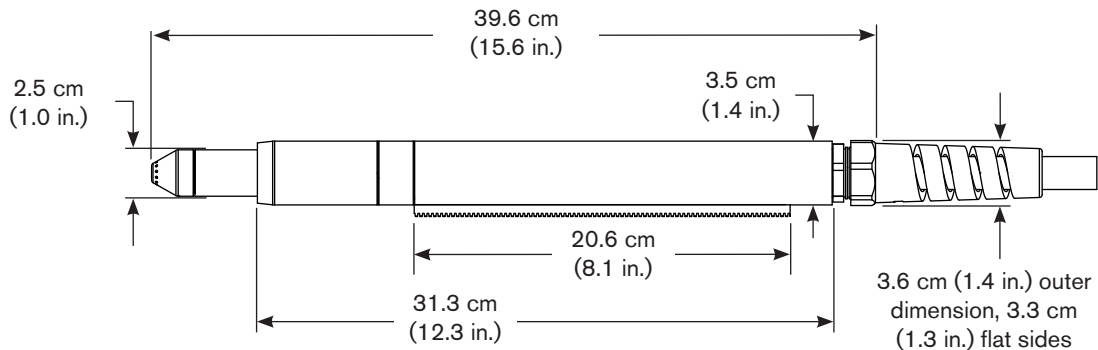

Duramax MRT₂ without positioning sleeve (mini torch) dimensions

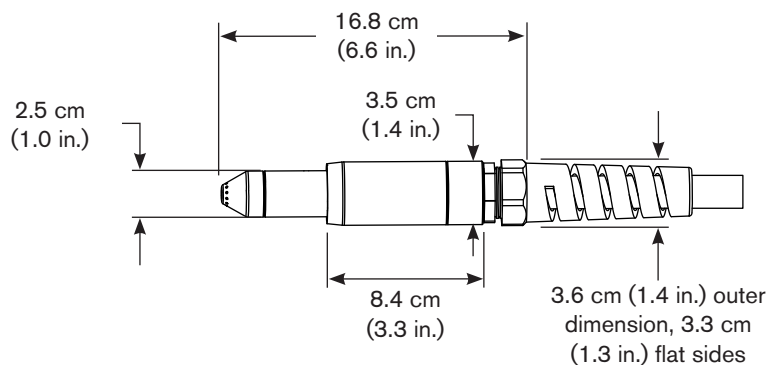

Section 2

Torch Setup

In this section:

Introduction	2-2
Consumable life.....	2-2
Hand torch setup	2-2
Choose the hand torch consumables	2-3
Install the hand torch consumables.....	2-4
Machine torch setup.....	2-5
Converting a Duramax retrofit machine torch into a mini torch	2-6
Mount the torch.....	2-8
Choose the machine torch consumables	2-10
Install the machine torch consumables	2-12
Aligning the torch	2-12
Torch installation	2-13
Torches with a quick disconnect connector	2-13
Torches without a quick disconnect connector - Powermax600 CE	2-14
ON/OFF Pendant connection	2-15

Introduction

Duramax™ series handheld and machine retrofit torches are available for the Powermax600, Powermax800, Powermax900, MAX42, and MAX43 systems. The torches are cooled by ambient air and do not require special cooling procedures.

This section explains how to setup your torch and choose the appropriate consumables for the job.

Consumable life

How often you need to change the consumables on your retrofit torch will depend on a number of factors:

- Thickness of the material – the thicker the material being cut, the more often consumables need to be changed.
- Average length of cut – the longer the average cut, the more often consumables need to be changed.
- Type of cutting – handheld cutting will require more consumable changes than machine cutting.
- Air quality – the presence of oil, moisture, or other contaminants will reduce consumable life.
- Piercing / edge starting – piercing the metal causes more consumable wear than starting cuts from the edge of the metal.
- Proper torch-to-work distance – when gouging or cutting with unshielded consumables, maintaining proper torch-to-work distance will result in better consumable life.
- Proper pierce height – maintaining proper pierce height will result in better consumable life.
- Cutting in “continuous pilot arc” mode or normal cutting mode – cutting with a continuous pilot arc causes more consumable wear than cutting in normal cutting mode.

You will find more information about proper cutting techniques in Section 3, *Operation*.

Hand torch setup

Duramax HRT₂

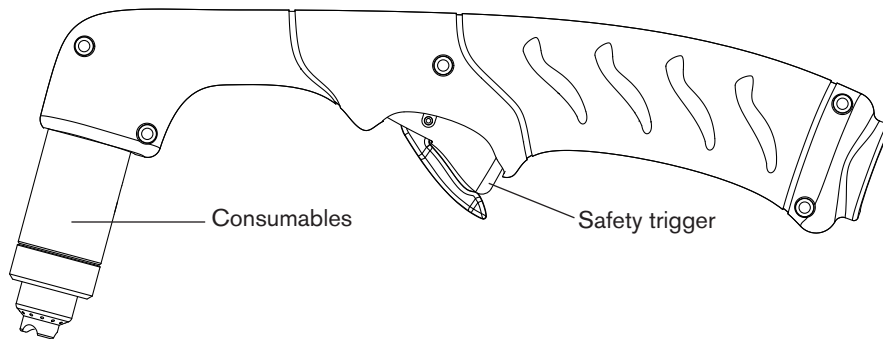

Choose the hand torch consumables

Duramax retrofit torches are shipped with a full set of cutting consumables pre-installed. Hypertherm also includes spare cutting electrodes, nozzles, and gouging consumables in the consumables box, for handheld torches.

Consumables for handheld cutting are shown on the next page. Notice that the retaining cap and electrode are the same for cutting, gouging, and FineCut® applications. Only the shield, nozzle, and swirl ring are different.

For the best cut quality on thin materials, you may prefer to use FineCut consumables, or use a 45 A nozzle and reduce the current setting to 45 or 40 amps.

Hand torch consumables

Drag-cutting consumables

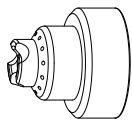

220818
Shield

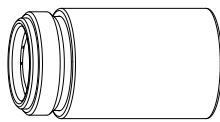

220854
Retaining cap



220941
Nozzle

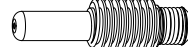

220842
Electrode

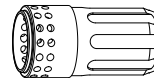

220857
Swirl ring

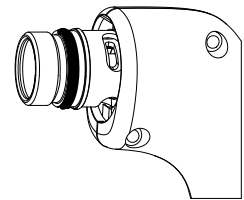

Gouging consumables

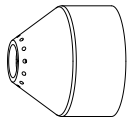

220798
Shield

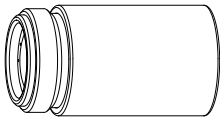

220854
Retaining cap

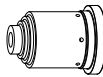

220797
Nozzle

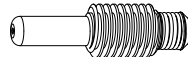

220842
Electrode

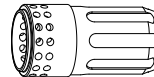

220857
Swirl ring

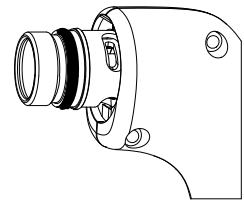

FineCut® consumables

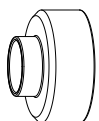

220931
Shield

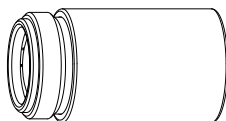

220854
Retaining cap



220930
Nozzle

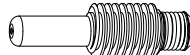

220842
Electrode

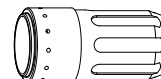

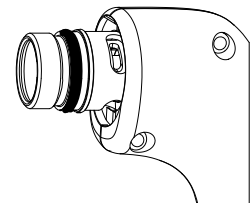

220947
Swirl ring



TORCH SETUP

Install the hand torch consumables

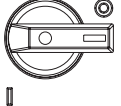
		<p style="text-align: center;">WARNING INSTANT-ON TORCHES PLASMA ARC CAN CAUSE INJURY AND BURNS</p>
	<p>The plasma arc comes on immediately when the torch trigger is activated. Make sure the power is OFF before changing consumables.</p>	

To operate the hand torch, a complete set of consumable parts must be installed: shield, retaining cap, nozzle, electrode, and swirl ring.

With the power switch in the OFF (O) position, install the torch consumables as shown below.

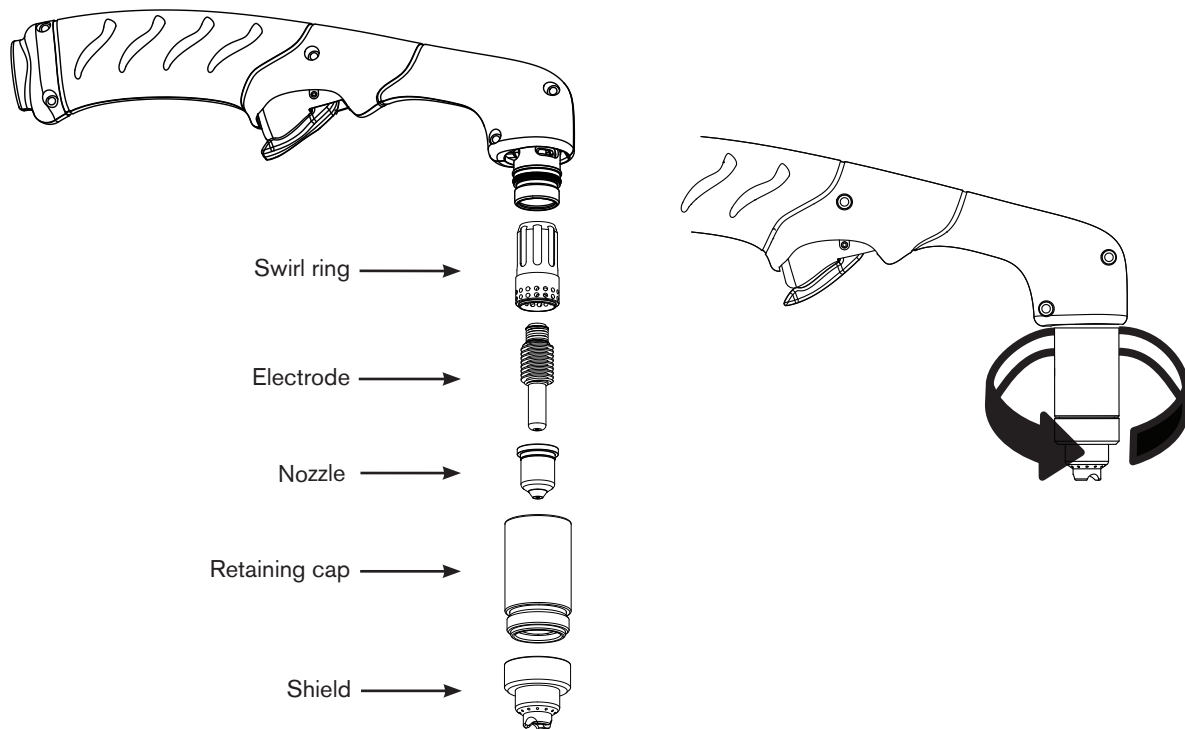

Machine torch setup

Duramax MRT₂

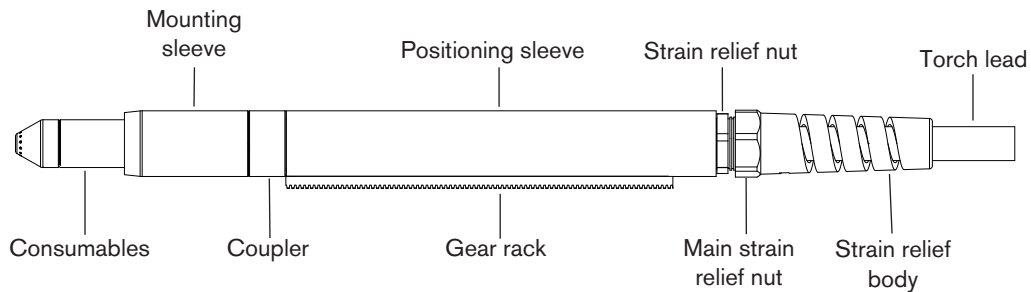

Duramax MRT₂ without positioning sleeve (mini torch)

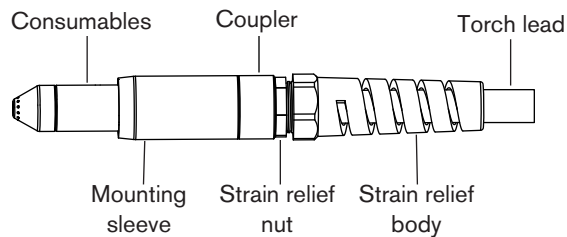

Before using either style of machine torch, you must:

- Mount the torch on your cutting table or other equipment.
- Choose and install the consumables.
- Align the torch.
- Attach the torch lead to the power supply.
- Set up the power supply for remote starting with either the remote-start pendant or a machine interface cable.

Converting a Duramax retrofit machine torch into a mini torch

You can convert a full-length machine torch to a mini-machine torch by removing the positioning sleeve. Refer to the figures on the previous page while completing the following instructions.

Note: If you are converting a full-length machine torch to a mini-machine torch *and* mounting the torch at the same time, skip this section and follow the instructions in the next section, "Mount the torch".

1. Disconnect the torch lead from the power supply and remove the consumables from the torch.

Note: While disconnecting and reconnecting the torch parts, maintain the same orientation between the torch body and torch lead. Twisting the torch body in relation to the torch lead can cause damage.

2. Unscrew the strain relief body from the strain relief nut and slide the strain relief body back along the torch lead.
3. Unscrew the strain relief nut from the positioning sleeve and slide the nut back along the torch lead.
4. Unscrew the positioning sleeve from the coupler.
5. Unscrew the coupler from the mounting sleeve.
6. Remove the three screws from the consumables end of the mounting sleeve and slide the mounting sleeve off the front of the torch body.
7. Disconnect the wire connector for the cap-sensor switch.
8. Use a #2 Phillips screwdriver to remove the screw that secures the pilot arc wire to the torch body.
9. Use 1/4-inch and 3/8-inch wrenches, or two adjustable wrenches, to loosen the nut that secures the gas supply line to the torch body. Set the torch body aside.
10. Slide the coupler and positioning sleeve off the front of the torch lead.

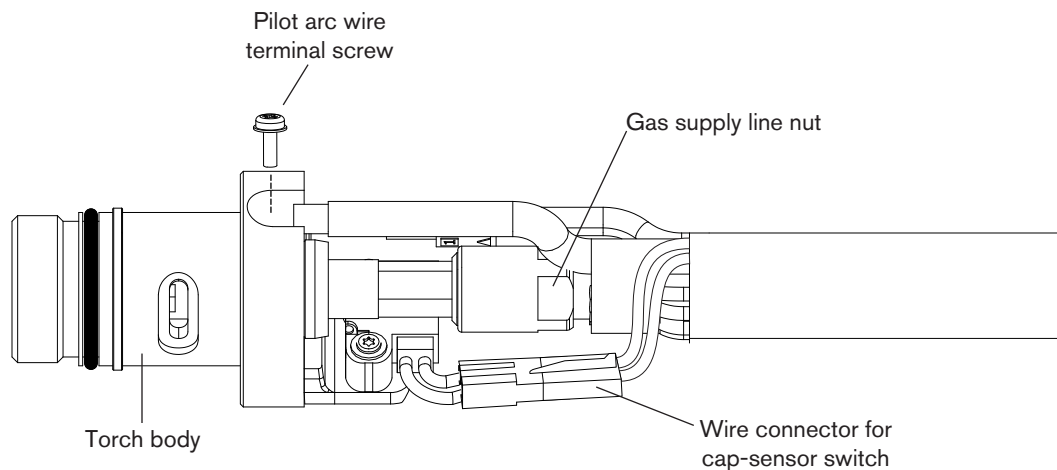

11. Slide the coupler over the torch lead.
12. Use two wrenches to tighten the gas supply line nut onto the threaded torch body fitting.
13. Secure the pilot arc wire to the torch body by tightening the pilot arc wire terminal screw.
14. Reconnect the cap-sensor switch's wire connector.
15. Slide the mounting sleeve over the front of the torch body. Align the slot on the front of the mounting sleeve (next to one of the three screw holes) with the cap-sensor plunger on the torch body.
16. Secure the mounting sleeve to the torch body by tightening the three screws.
17. Screw the coupler into the mounting sleeve.
18. Screw the strain relief nut into the coupler.
19. Screw the strain relief body into the strain relief nut.

Mount the torch

Depending on the type of cutting table you have, you may or may not need to disassemble the torch to route it through the track and mount it. If your cutting table's track is large enough for you to thread the torch through it without removing the torch body from the lead, do so and then attach the torch to the lifter per the manufacturer's instructions.

Note: The Duramax machine torches can be mounted on a wide variety of X-Y tables, track burners, pipe bevelers, and other equipment. Install the torch per the manufacturer's instructions and follow the instructions below for disassembly if necessary.

If you need to disassemble and reassemble the torch, refer to the figures in the "Machine torch setup" section while completing the following instructions.

1. Disconnect the torch lead from the power supply and remove the consumables from the torch.

Note: While disconnecting and reconnecting the torch parts, maintain the same orientation between the torch body and torch lead. Twisting the torch body in relation to the torch lead can cause damage.

2. Unscrew the strain relief body from the strain relief nut and slide the strain relief body back along the torch lead.
3. Unscrew the strain relief nut from the positioning sleeve (full-length machine torch) and slide the nut back along the torch lead.
4. Unscrew the positioning sleeve from the coupler.
5. Unscrew the coupler from the mounting sleeve.
6. Remove the three screws from the consumables end of the mounting sleeve and slide the mounting sleeve off the front of the torch body.
7. Disconnect the wire connector for the cap-sensor switch.
8. Use a #2 Phillips screwdriver to remove the screw that secures the pilot arc wire to the torch body.

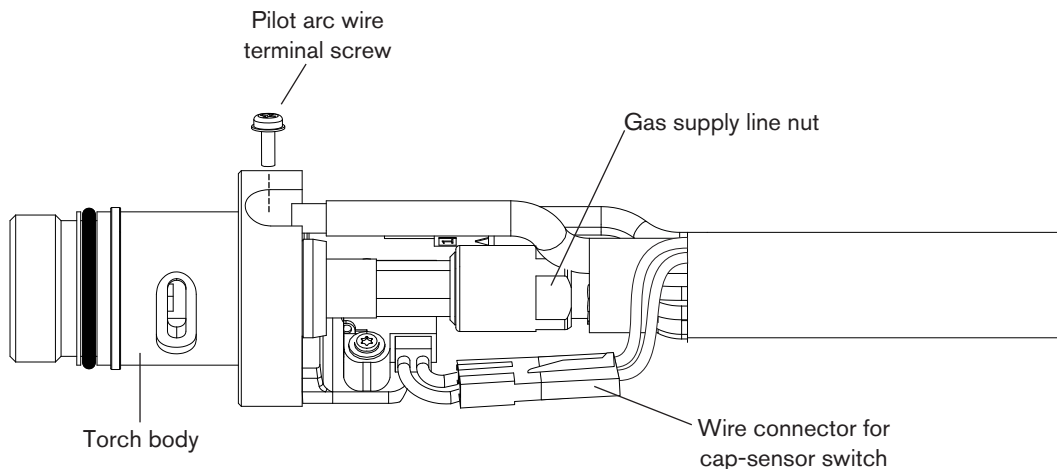

9. Use 1/4-inch and 3/8-inch wrenches, or two adjustable wrenches, to loosen the nut that secures the gas supply line to the torch body. Set the torch body aside.

Note: Cover the end of the gas line on the torch lead with tape to keep dirt and other contaminants from getting in the gas line when you route the lead through the track.

10. Slide the coupler, positioning sleeve (full-length machine torch), strain relief nut, and strain relief body off the front of the torch lead.
11. If you do not need the gear rack on a full-length machine torch, slide the gear rack from the positioning sleeve toward the consumables end of the sleeve.
12. Route the torch lead through the cutting table's track.
13. Slide the strain relief body and strain relief nut over the torch lead.
14. If you are mounting a full-length machine torch, slide the positioning sleeve over the torch head.
15. Slide the coupler over the torch lead.
16. Use two wrenches to tighten the gas supply line nut onto the threaded torch body fitting.
17. Secure the pilot arc wire to the torch body by tightening the pilot arc wire terminal screw.
18. Reconnect the cap-sensor switch's wire connector.
19. Slide the mounting sleeve over the front of the torch body. Align the slot on the front of the mounting sleeve (next to one of the three screw holes) with the cap-sensor plunger on the torch body.
20. Secure the mounting sleeve to the torch body by tightening the three screws.
21. Screw the coupler into the mounting sleeve.
22. If you are mounting a full-length machine torch, screw the positioning sleeve into the coupler.
23. Reconnect the strain relief nut and strain relief body.
24. Attach the torch to the lifter per the manufacturer's instructions.

TORCH SETUP

Choose the machine torch consumables

Powermax systems with the Duramax MRT₂ retrofit torch are shipped with a complete set of consumables. Hypertherm also includes spare electrodes and nozzles. In addition, an ohmic-sensing retaining cap is available for use with shielded consumables. With shielded consumables, the torch tip may touch the metal when cutting. With unshielded consumables, you must keep the torch a small distance, about 2 mm (0.08 inch), away from the metal. Unshielded consumables generally have a shorter life than shielded consumables.

Machine torch consumables

Mechanized shielded consumables

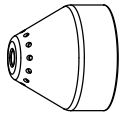

220817
Shield

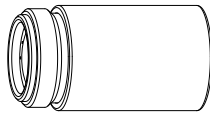

220854
Retaining cap



220941
Nozzle

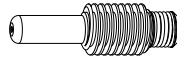

220842
Electrode

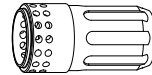

220857
Swirl ring

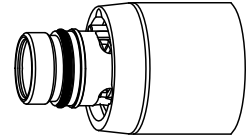

Mechanized shielded with ohmic consumables

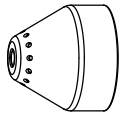

220817
Shield

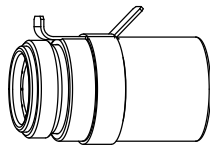

220953
Ohmic-sensing
retaining cap



220941
Nozzle

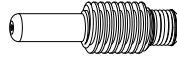

220842
Electrode

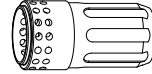

220857
Swirl ring

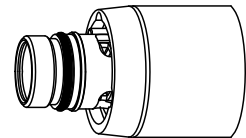

Mechanized unshielded consumables

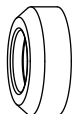

220955
Deflector

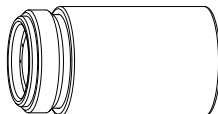

220854
Retaining cap



220941
Nozzle

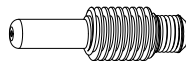

220842
Electrode

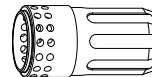

220857
Swirl ring

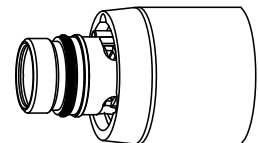

Gouging consumables

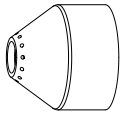

220798
Shield

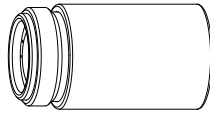

220854
Retaining cap

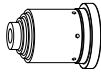

220797
Nozzle

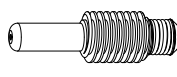

220842
Electrode

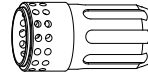

220857
Swirl ring

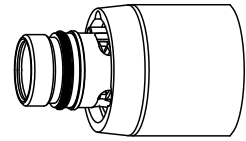

FineCut® shielded

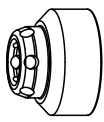

220948
Shield

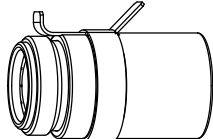

220953
Retaining cap



220930
Nozzle

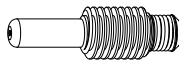

220842
Electrode

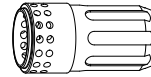

220857
Swirl ring

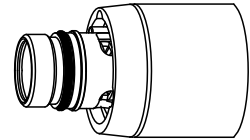

FineCut® unshielded consumables

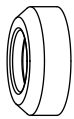

220955
Deflector

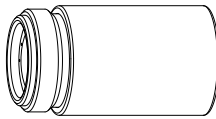

220854
Retaining cap



220930
Nozzle

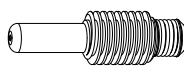

220842
Electrode

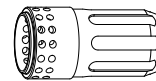

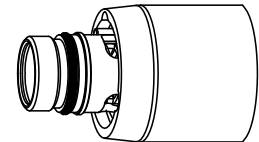

220857
Swirl ring



TORCH SETUP

Install the machine torch consumables

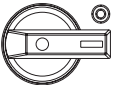
		<p style="text-align: center;">WARNING INSTANT-ON TORCHES PLASMA ARC CAN CAUSE INJURY AND BURNS</p>
	<p>The plasma arc comes on immediately when the torch is activated. Make sure the power is OFF before changing the consumables.</p>	

To operate the machine torch, a complete set of consumable parts must be installed: shield, retaining cap, nozzle, electrode, and swirl ring.

With the power switch in the OFF (O) position, install the machine torch consumables in a manner similar to the hand torch consumables. Refer to “Install the hand torch consumables” on page 2-4.

Aligning the torch

Mount the machine torch perpendicular to the workpiece in order to get a vertical cut. Use a square to align the torch at 0° and 90°.

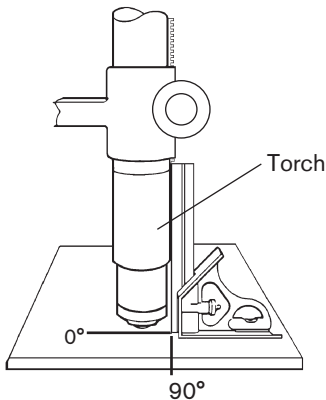

Torch installation

Torches with a quick disconnect connector

1. Turn OFF the power switch and remove the power cord from the power receptacle.

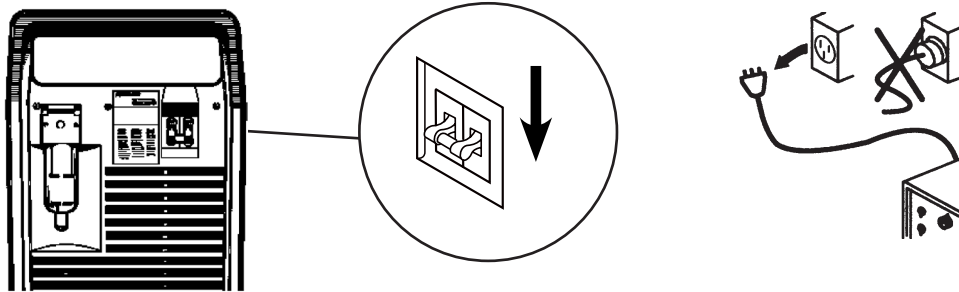

2. Disconnect the gas supply hose from the power supply.
3. Align the connector key-way on the torch lead with the receptacle on the power supply and push in until the pins seat.
4. Before tightening, turn the connector securing ring 1/4 turn to the left to ensure that the securing ring threads and the connector receptacle threads are aligned.
5. Turn the securing ring to the right to tighten.
6. Clean the top of the power supply and apply the new consumable label over the existing label.

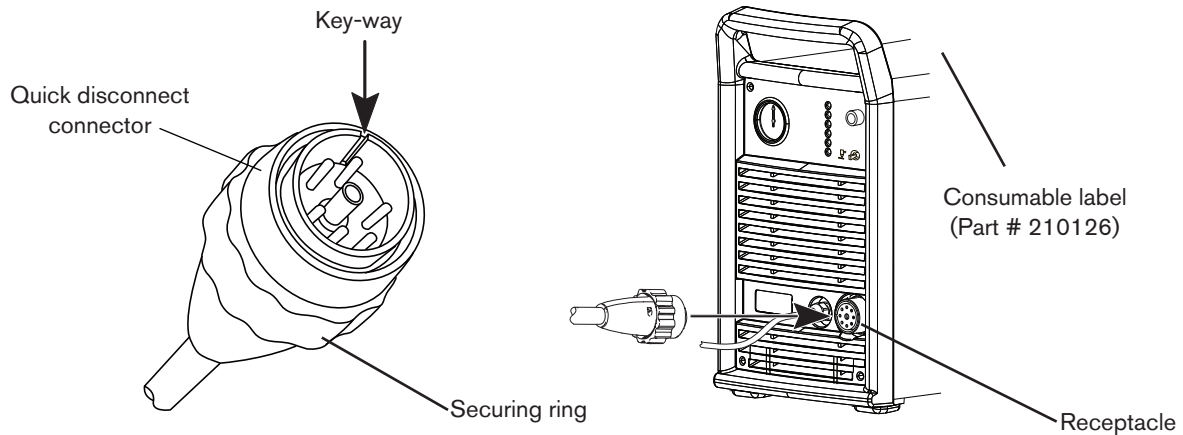

Note: If the receptacle is missing or damaged it should be replaced with a new receptacle.

Part Number	Description
028522	MAX42 receptacle
028523	MAX43 receptacle
029962	Powermax800 receptacle
128493	Powermax600 receptacle
129325	Powermax900 receptacle

TORCH SETUP

Torches without a quick disconnect connector - Powermax600 CE

1. Turn OFF the power switch and remove the power cord from the power receptacle.

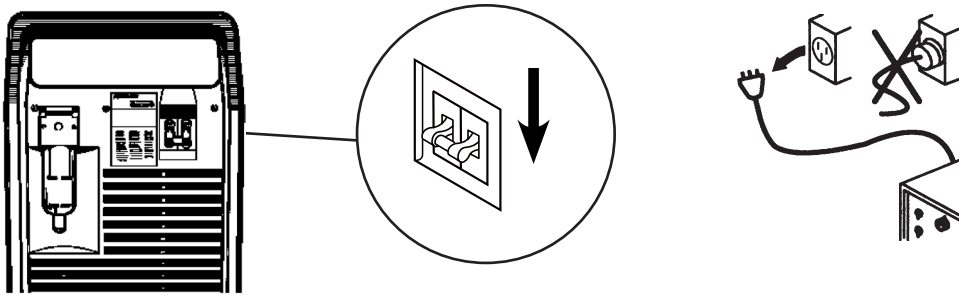

2. Disconnect the gas supply hose from the power supply.

Caution: Do not tighten the strain relief collar (4) onto the torch lead until the gas fitting (3) is tight, or the gas connection may leak.

3. Install the strain relief (1) and secure with nut (2).
4. Connect and tighten the gas fitting (3).
5. Tighten the strain relief collar (4) onto the lead.
6. Connect the electrical connections (5), (6) and (7). Tighten the terminal block screws to 12 kg cm (10 in.-lb).

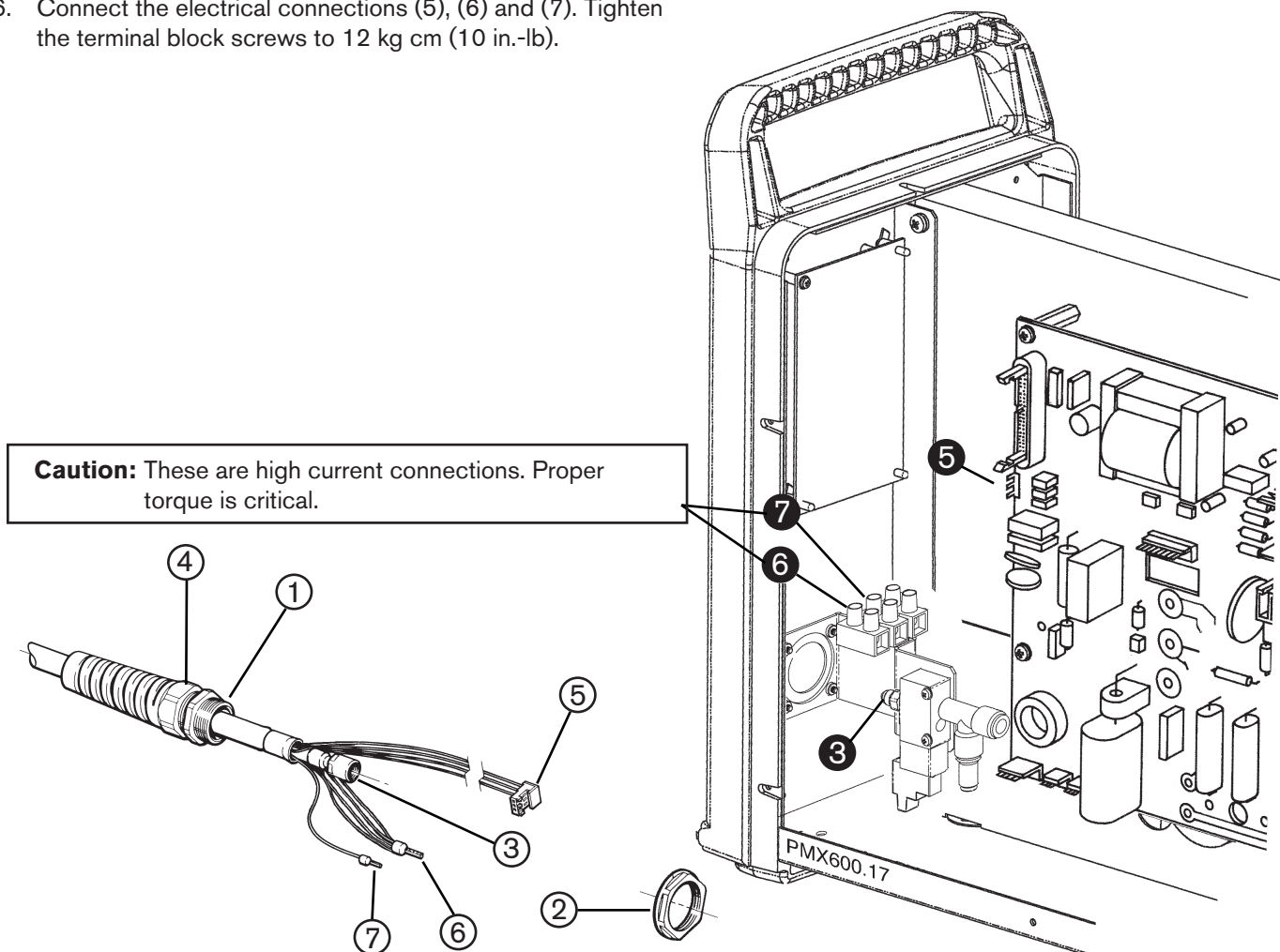

ON/OFF Pendant connection

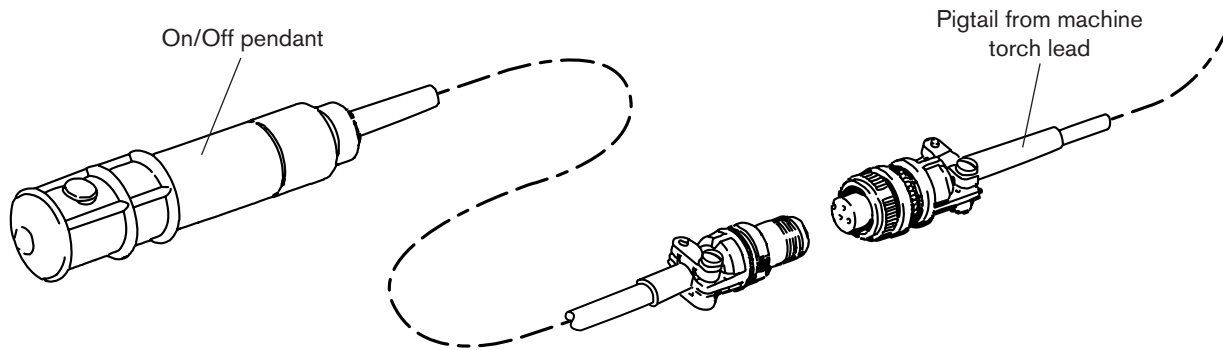

The Duramax MRT₂ torch lead is supplied with a pigtail so that the on/off pendant may be used. If you want to use a different on/off switch configuration, note that the wiring configuration to the 3-socket female receptacle on the pigtail is as follows:

Socket A	White Wire
Socket B	Not Used
Socket C	Black Wire

Section 3

Operation

In this section:

Using the cut charts	3-2
55 amp mechanized shielded consumables	3-3
50 amp mechanized shielded consumables	3-4
45 amp mechanized shielded consumables	3-5
40 amp mechanized shielded consumables	3-8
45 amp mechanized unshielded consumables	3-9
40 amp mechanized unshielded consumables	3-12
FineCut® consumables	3-13
Using the hand torch	3-17
Operate the safety trigger	3-17
Hand torch cutting hints	3-18
Start a cut from the edge of the workpiece	3-19
Pierce a workpiece	3-20
Gouge a workpiece	3-21
General guidelines for gouging	3-22
Common hand-cutting faults	3-22
Using the machine torch	3-23
Ensure the torch and table are set up correctly	3-23
Understand and optimize cut quality	3-23
To pierce a workpiece using the machine torch	3-26
Common machine-cutting faults	3-26

Using the cut charts

The following sections provide cut charts for each set of mechanized consumables. A consumable diagram with part numbers precedes each cut chart.

The cut charts are intended to provide a good starting point for each different cut assignment. Every cutting system requires “fine tuning” for each cutting application in order to obtain the desired cut quality.

The arc voltage increases as the consumables wear and the voltage setting should be increased to maintain the correct Torch-to-Work Distance.

The 45 amp nozzle (part number 220941) provides the best results across the 40 - 55 amp cutting range for both the mechanized shielded and unshielded consumables.

Note: Hypertherm collected the data under laboratory test conditions using new consumables.

- Maximum travel speeds are the fastest travel speeds possible to cut the material without regard to cut quality.
- Optimum travel speeds provide the best cut angle, least dross and best cut surface finish.
- Best Quality Settings (cut speed and voltage) — Settings that provide the starting point for finding the best cut quality (best angle, least dross, best cut-surface finish). Adjust the speed for your application and table to obtain the desired result.
- Production Settings (cut speed and voltage) — 80% of the maximum speed ratings. These speeds result in the greatest number of cut parts, but not necessarily the best possible cut quality.

55 amp mechanized shielded consumables

▪ Torch-to-work distance for the following cut chart is 1.5 mm (1/16 inch) for all cuts.

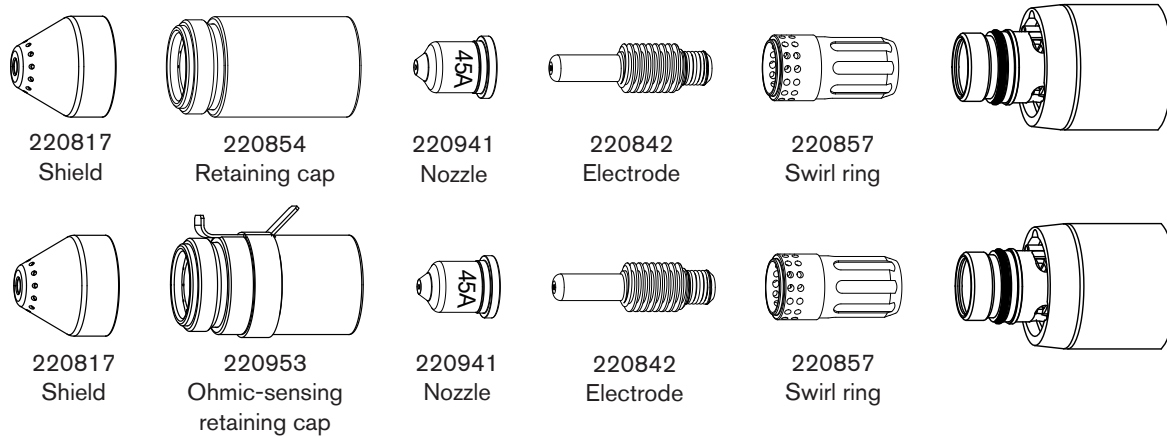

Mild Steel								
Arc Current	Arc Voltage	Motion Delay	Material Thickness		Maximum Travel Speeds		Optimum Travel Speeds	
			Inches	mm	IPM	mm/min	IPM	mm/min
55	134	0	16 Ga	1.5	627	15926	502	12751
	127		10 Ga	3.4	264	6706	211	5359
	134	0.25	1/4"	6.4	118	2997	78	1981
	138	0.75	3/8"	9.5	61	1549	39	991
	144	*	1/2"	12.7	41	1041	26	660
	146		5/8"	15.9	28	711	18	457
	149		3/4"	19.0	19	483	12	305
Stainless								
Arc Current	Arc Voltage	Motion Delay	Material Thickness		Maximum Travel Speeds		Optimum Travel Speeds	
			Inches	mm	IPM	mm/min	IPM	mm/min
55	134	0	16 Ga	4.8	625	15875	406	10312
	136	0.25	10 Ga	3.4	244	6198	159	4039
	139	0.50	1/4"	6.4	98	2489	64	1626
	145	0.75	3/8"	9.5	51	1295	32	813
	146	*	1/2"	12.7	34	864	22	559
	149		5/8"	15.9	23	584	15	381
	154		3/4"	19.0	15	381	10	254
Aluminum								
Arc Current	Arc Voltage	Motion Delay	Material Thickness		Maximum Travel Speeds		Optimum Travel Speeds	
			Inches	mm	IPM	mm/min	IPM	mm/min
55	135	0	1/16"	1.6	666	16916	433	10998
	138	0.25	1/8"	3.2	400	10160	260	6604
	141		1/4"	6.4	129	3277	83	2108
	146	0.75	3/8"	9.5	71	1803	46	1168
	149	*	1/2"	12.7	50	1270	29	737
	153		5/8"	15.9	29	737	18	457

* Piercing material in this range is not recommended, it will shorten consumable life. Starting cuts at the edge of the metal is recommended.

OPERATION

50 amp mechanized shielded consumables

▪ Torch-to-work distance for the following cut chart is 1.5 mm (1/16 inch) for all cuts.

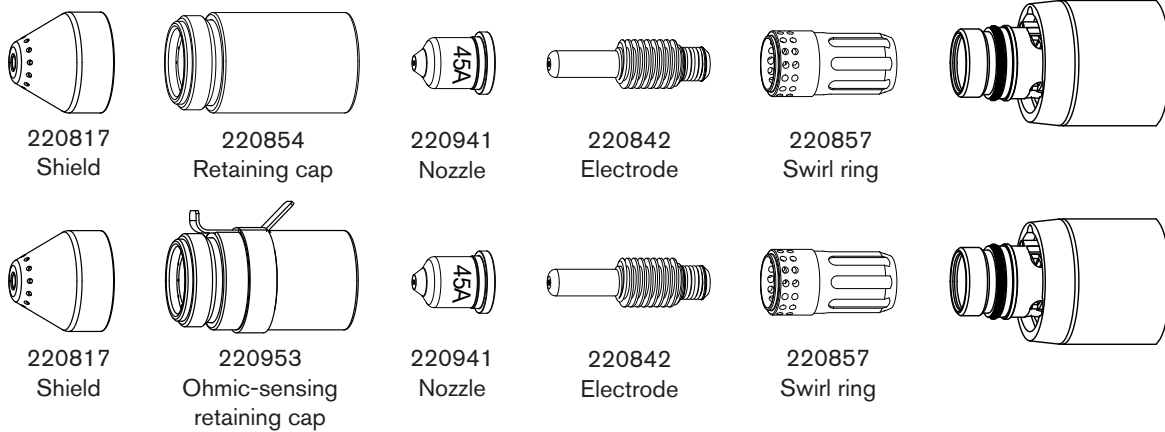

Mild Steel								
Arc Current	Arc Voltage	Motion Delay	Material Thickness		Maximum Travel Speeds		Optimum Travel Speeds	
			Inches	mm	IPM	mm/min	IPM	mm/min
50	134	0	16 Ga	1.5	627	15926	502	12751
	128		10 Ga	3.4	230	5842	184	4674
	132	0.25	1/4"	6.4	100	2540	65	1651
	136	0.75	3/8"	9.5	50	1270	33	838
	145	*	1/2"	12.7	32	813	20	508
	151		5/8"	15.9	23	584	15	381
	157		3/4"	19.0	15	381	9	229
Stainless								
Arc Current	Arc Voltage	Motion Delay	Material Thickness		Maximum Travel Speeds		Optimum Travel Speeds	
			Inches	mm	IPM	mm/min	IPM	mm/min
50	134	0	16 Ga	4.8	625	15875	406	10312
	136	0.25	10 Ga	3.4	213	5410	139	3531
	139	0.50	1/4"	6.4	83	2108	54	1372
	145	0.75	3/8"	9.5	42	1067	27	686
	146	*	1/2"	12.7	26	660	17	432
	149		5/8"	15.9	19	483	12	305
	154		3/4"	19.0	12	305	8	203
Aluminum								
Arc Current	Arc Voltage	Motion Delay	Material Thickness		Maximum Travel Speeds		Optimum Travel Speeds	
			Inches	mm	IPM	mm/min	IPM	mm/min
50	135	0	1/16"	1.6	666	16916	433	10998
	138	0.25	1/8"	3.2	400	10160	260	6604
	141		1/4"	6.4	110	2794	71	1803
	146	0.75	3/8"	9.5	58	1473	37	940
	149	*	1/2"	12.7	39	991	23	584
	153		5/8"	15.9	24	610	15	381

* Piercing material in this range is not recommended, it will shorten consumable life. Starting cuts at the edge of the metal is recommended.

45 amp mechanized shielded consumables

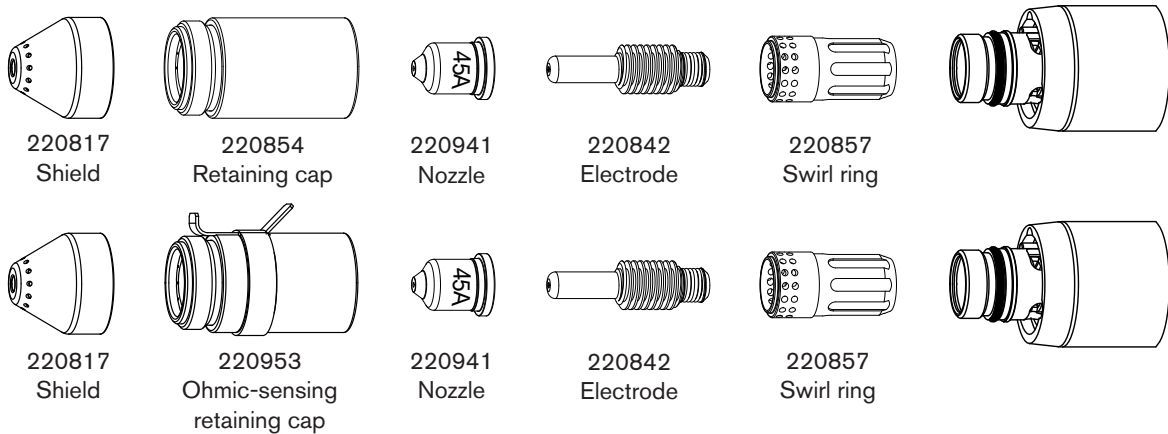

**45A Shielded
Mild Steel**

Air flow rate - slpm/scfh	
Hot	177 / 376
Cold	201 / 427

Metric

Material Thickness	Torch-to-Work Distance	Initial Pierce Height		Pierce Delay Time	Best Quality Settings		Production Settings		
					Cut Speed	Voltage	Cut Speed	Voltage	
mm	mm	mm	%	seconds	(mm/min)	Volts	(mm/min)	Volts	
0.5	1.5	3.8	250	0.0	9000	128	12500	126	
1					9000	128	10800	128	
1.5					9000	130	10200	129	
2					6600	130	7800	129	
3					0.4	3850	133	4900	131
4						2200	134	3560	131
6						1350	137	2050	132

English

Material Thickness	Torch-to-Work Distance	Initial Pierce Height		Pierce Delay Time	Best Quality Settings		Production Settings		
					Cut Speed	Voltage	Cut Speed	Voltage	
inches	inches	inches	%	seconds	ipm	Volts	ipm	Volts	
26GA	0.02	0.08	400	0.0	350	128	500	128	
22GA					350	128	450	128	
18GA					0.1	350	129	400	128
16GA						350	130	400	129
14GA	0.06	0.15	250	0.2	270	130	320	129	
12GA				0.4	190	133	216	131	
10GA					100	134	164	131	
3/16				0.5	70	135	108	132	
1/4				0.6	48	137	73	132	

OPERATION

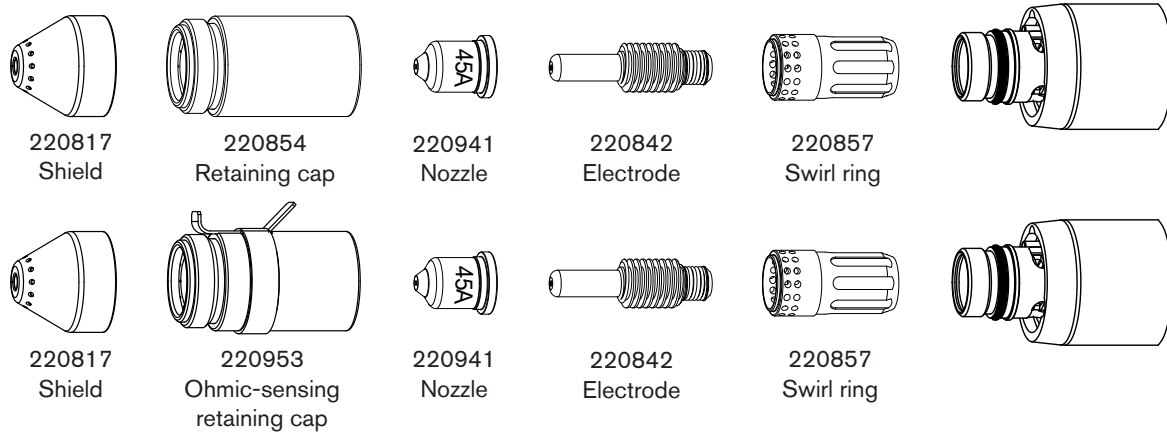

45A Shielded Stainless Steel

Air flow rate - slpm/scfh	
Hot	177 / 376
Cold	201 / 427

Metric

Material Thickness	Torch-to-Work Distance	Initial Pierce Height		Pierce Delay Time	Best Quality Settings		Production Settings	
					Cut Speed	Voltage	Cut Speed	Voltage
mm	mm	mm	%	seconds	(mm/min)	Volts	(mm/min)	Volts
0.5	1.5	3.8	250	0.0	9000	130	12500	129
1					9000	130	10800	130
1.5				9000	130	10200	130	
2				6000	132	8660	131	
3				0.4	3100	132	4400	132
4					2000	134	2600	134
6				0.5	900	140	1020	139

English

Material Thickness	Torch-to-Work Distance	Initial Pierce Height		Pierce Delay Time	Best Quality Settings		Production Settings	
					Cut Speed	Voltage	Cut Speed	Voltage
	inches	inches	%	seconds	ipm	Volts	ipm	Volts
26GA	0.02	0.08	400	0.0	350	130	500	129
22GA					350	130	450	129
18GA				0.1	350	130	400	130
16GA					350	130	400	130
14GA	0.06	0.15	250	0.2	250	132	360	131
12GA				0.4	140	132	206	131
10GA					100	133	134	134
3/16 in.				0.5	52	135	58	135
1/4 in.				0.6	30	141	35	140

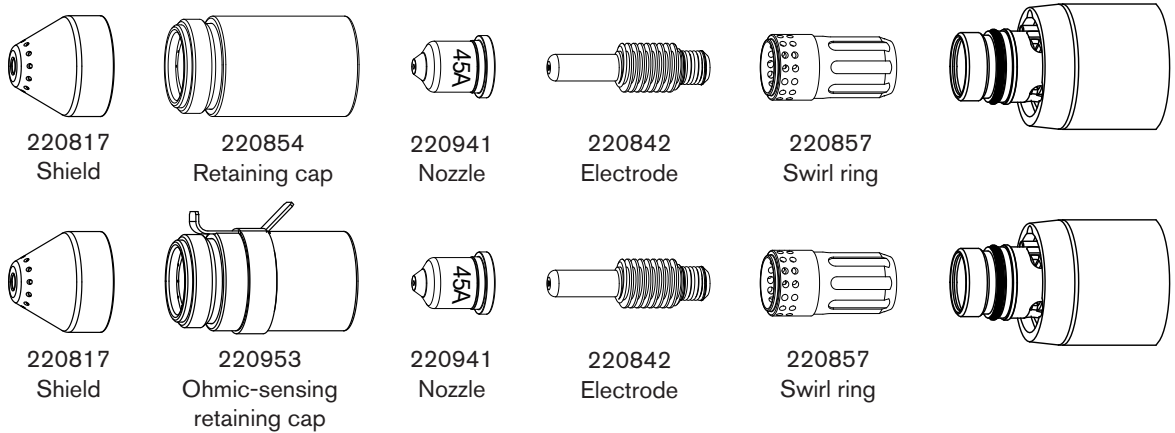

**45A Shielded
Aluminum**

Air flow rate - slpm/scfh	
Hot	177 / 376
Cold	201 / 427

Metric

Material Thickness	Torch-to-Work Distance	Initial Pierce Height		Pierce Delay Time	Best Quality Settings		Production Settings	
					Cut Speed	Voltage	Cut Speed	Voltage
mm	mm	mm	%	seconds	(mm/min)	Volts	(mm/min)	Volts
1	1.5	3.8	250	0.0	8250	136	11000	136
2				0.1	6600	136	9200	135
3				0.2	3100	139	6250	134
4				0.4	2200	141	4850	135
6				0.5	1500	142	2800	137

English

Material Thickness	Torch-to-Work Distance	Initial Pierce Height		Pierce Delay Time	Best Quality Settings		Production Settings	
					Cut Speed	Voltage	Cut Speed	Voltage
inches	inches	inches	%	seconds	ipm	Volts	ipm	Volts
1/32	0.06	0.15	250	0.0	325	136	450	136
1/16				0.1	325	136	400	136
3/32				0.2	200	136	328	134
1/8				0.4	100	140	224	134
1/4				0.5	54	142	96	137

OPERATION

40 amp mechanized shielded consumables

▪ Torch-to-work distance for the following cut chart is 1.5 mm (1/16 inch) for all cuts.

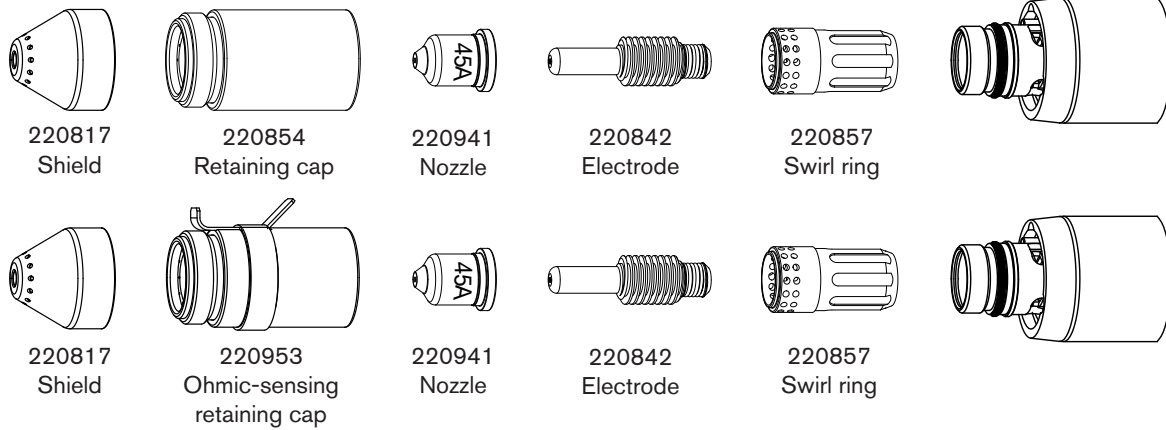

Mild Steel								
Arc Current	Arc Voltage	Motion Delay	Material Thickness		Maximum Travel Speeds		Optimum Travel Speeds	
			Inches	mm	IPM	mm/min	IPM	mm/min
25	147	0	26 GA	0.5	638	16205	415	10541
	148		22 GA	0.8	500	12700	325	8255
	149		18 GA	1.3	312	7925	203	5156
	152		16 GA	1.5	176	4470	114	2896
40	144	0.25	14 GA	1.9	640	16256	221	5613
	146	0.50	10 GA	3.4	151	3835	98	2489
	147	0.75	3/16	4.7	97	2464	63	1600
	149	1.00	1/4	6.4	74	1880	48	1219
Stainless								
Arc Current	Arc Voltage	Motion Delay	Material Thickness		Maximum Travel Speeds		Optimum Travel Speeds	
			Inches	mm	IPM	mm/min	IPM	mm/min
25	139	0	26 GA	0.5	631	16027	410	10414
	139		22 GA	0.8	496	12598	322	8179
40	142	0.25	18 GA	1.3	592	15037	335	8509
	144		16 GA	1.5	374	9500	243	6172
	144		14 GA	1.9	221	5613	144	3658
	147	0.50	10 GA	3.4	107	2718	70	1778
	149	0.75	3/16	4.7	67	1702	44	1118
	149	1.00	1/4	6.4	47	1194	31	787
Aluminum								
Arc Current	Arc Voltage	Motion Delay	Material Thickness		Maximum Travel Speeds		Optimum Travel Speeds	
			Inches	mm	IPM	mm/min	IPM	mm/min
25	150	0	1/32	0.8	610	15494	397	10084
	152		1/16	1.5	268	6807	174	4420
40	146	0.25	3/32	2.4	293	7442	190	4826
	149	0.50	1/8	3.2	204	5182	133	3378
	151	1.00	1/4	6.4	76	1930	49	1245

45 amp mechanized unshielded consumables

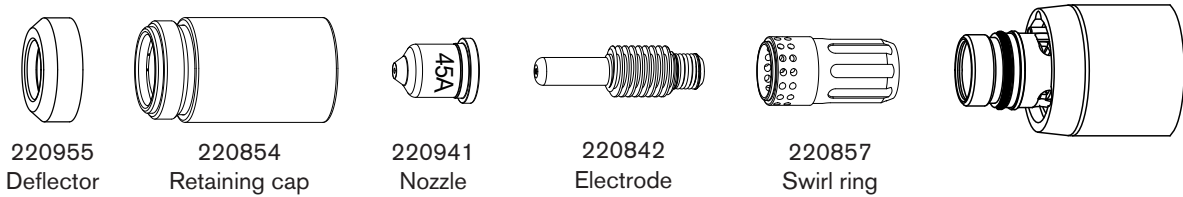

45A Unshielded

Mild Steel

Air flow rate - slpm/scfh	
Hot	177 / 376
Cold	201 / 427

Metric

Material Thickness	Torch-to-Work Distance	Initial Pierce Height		Pierce Delay Time	Best Quality Settings		Production Settings	
					Cut Speed	Voltage	Cut Speed	Voltage
mm	mm	mm	%	seconds	(mm/min)	Volts	(mm/min)	Volts
0.5	1.5	3.8	250	0.0	9000	120	12500	120
1					9000	120	10800	121
1.5				7700	120	10200	121	
2				6150	119	7800	122	
3				0.4	3950	121	4900	123
4					2350	123	3560	124
6				0.5	1400	126	2050	124

English

Material Thickness	Torch-to-Work Distance	Initial Pierce Height		Pierce Delay Time	Best Quality Settings		Production Settings	
					Cut Speed	Voltage	Cut Speed	Voltage
	inches	inches	%	seconds	ipm	Volts	ipm	Volts
26GA	0.06	0.15	250	0.0	350	120	500	120
22GA					350	120	450	120
18GA				0.1	350	119	400	121
16GA					300	121	400	121
14GA				0.2	250	119	320	122
12GA				0.4	200	120	216	123
10GA					100	123	164	124
3/16 in.				0.5	85	122	108	124
1/4 in.	0.6	48	127	73	124			

OPERATION

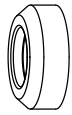

220955
Deflector

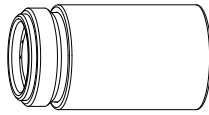

220854
Retaining cap



220941
Nozzle

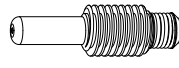

220842
Electrode

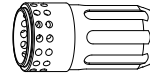

220857
Swirl ring

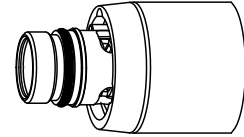

45A Unshielded Stainless Steel

Air flow rate - slpm/scfh

Hot	177 / 376
Cold	201 / 427

Metric

Material Thickness	Torch-to-Work Distance	Initial Pierce Height		Pierce Delay Time	Best Quality Settings		Production Settings	
					Cut Speed	Voltage	Cut Speed	Voltage
mm	mm	mm	%	seconds	(mm/min)	Volts	(mm/min)	Volts
0.5	1.5	3.8	250	0.0	9000	121	12500	119
1					9000	121	10800	119
1.5				0.1	9000	121	10200	120
2				0.3	6000	122	9600	120
3					3250	123	4750	120
4				0.4	1900	128	3000	122
6					700	130	1450	124

English

Material Thickness	Torch-to-Work Distance	Initial Pierce Height		Pierce Delay Time	Best Quality Settings		Production Settings	
					Cut Speed	Voltage	Cut Speed	Voltage
	inches	inches	%	seconds	ipm	Volts	ipm	Volts
26GA	0.02	0.08	400	0.0	350	120	500	119
22GA					350	120	450	119
18GA				0.1	350	118	400	119
16GA					350	121	400	120
14GA	0.06	0.15	250	0.2	300	122	400	120
12GA				0.4	150	121	224	120
10GA					100	125	140	121
3/16 in.				0.5	42	131	88	123
1/4 in.				0.6	25	130	48	124

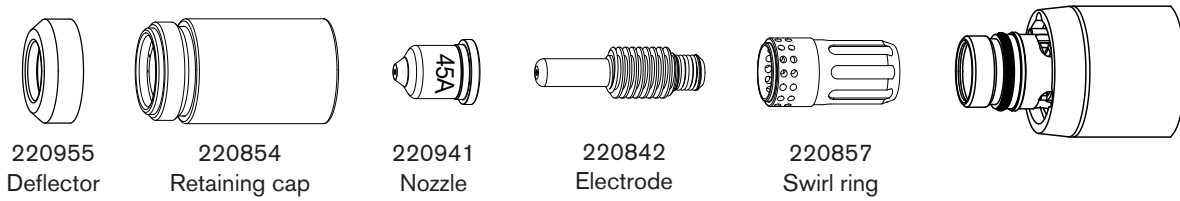

**45A Unshielded
Aluminum**

Air flow rate - slpm/scfh	
Hot	177 / 376
Cold	201 / 427

Metric

Material Thickness	Torch-to-Work Distance	Initial Pierce Height		Pierce Delay Time	Best Quality Settings		Production Settings	
					Cut Speed	Voltage	Cut Speed	Voltage
mm	mm	mm	%	seconds	(mm/min)	Volts	(mm/min)	Volts
1	1.5	3.8	250	0.0	7400	126	11000	121
2				0.1	4400	127	9200	123
3				0.2	2800	129	6250	125
4				0.4	2100	132	4700	126
6				0.5	1050	135	2250	127

English

Material Thickness	Torch-to-Work Distance	Initial Pierce Height		Pierce Delay Time	Best Quality Settings		Production Settings	
					Cut Speed	Voltage	Cut Speed	Voltage
inches	inches	inches	%	seconds	ipm	Volts	ipm	Volts
1/32	0.06	0.15	250	0.0	325	126	450	121
1/16				0.1	200	126	400	122
3/32				0.2	150	127	328	124
1/8				0.4	100	130	224	125
1/4				0.5	36	136	72	127

OPERATION

40 amp mechanized unshielded consumables

▪ Torch-to-work distance for the following cut chart is 1.5 mm (1/16 inch) for all cuts.

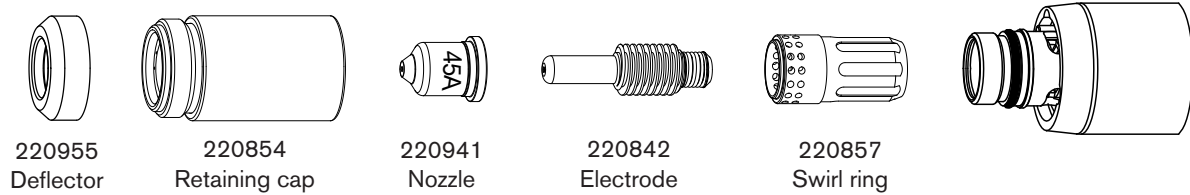

Mild Steel								
Arc Current	Arc Voltage	Motion Delay	Material Thickness		Maximum Travel Speeds		Optimum Travel Speeds	
			Inches	mm	IPM	mm/min	IPM	mm/min
25	125	0	26 GA	0.5	550	13970	353	8966
	128		22 GA	0.8	484	12294	315	8001
	130		18 GA	1.3	238	6045	155	3937
	131		16 GA	1.5	167	4242	109	2769
40	129	0.25	14 GA	1.9	326	8280	212	5385
Stainless								
Arc Current	Arc Voltage	Motion Delay	Material Thickness		Maximum Travel Speeds		Optimum Travel Speeds	
			Inches	mm	IPM	mm/min	IPM	mm/min
25	127	0	26 GA	0.5	561	14249	365	9271
	127		22 GA	0.8	453	11506	295	7493
40	123	0.25	18 GA	1.3	500	12700	325	8255
	127		16 GA	1.5	367	9322	239	6071
	128		14 GA	1.9	220	5588	143	3632
Aluminum								
Arc Current	Arc Voltage	Motion Delay	Material Thickness		Maximum Travel Speeds		Optimum Travel Speeds	
			Inches	mm	IPM	mm/min	IPM	mm/min
25	125	0	1/32	0.8	564	14326	366	9296
	127		1/16	1.5	236	5994	153	3886
40	127	0.25	3/32	2.4	261	6629	170	4318

FineCut® consumables

Note: The cut charts in this section apply to both shielded and unshielded consumables

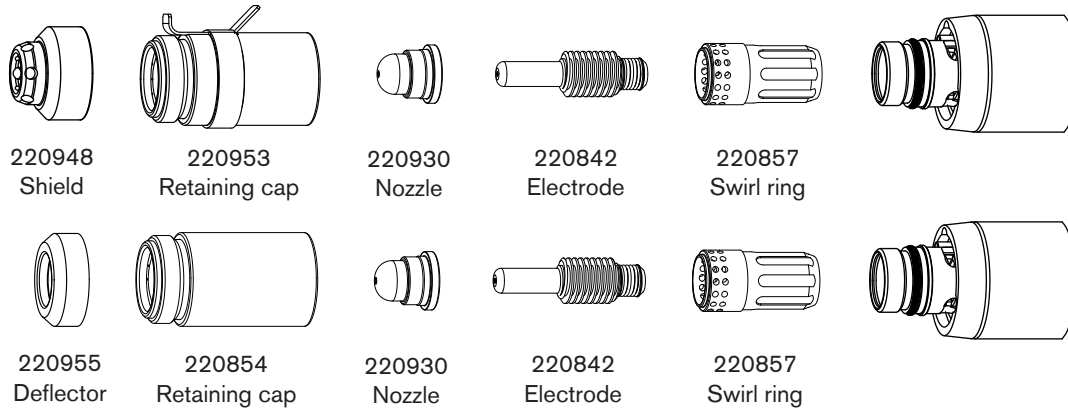

**FineCut
Mild Steel**

Metric

Material Thickness	Current	Torch-to-Work Distance	Initial Pierce Height		Pierce Delay Time	Recommended		
						Cut Speed	Voltage	
mm	A	mm	mm	%	seconds	(mm/min)	Volts	
0.5	40	1.5	2.25	150	0	8250	78	
0.6						8250	78	
0.8						8250	78	
1	45				0.1	8250	78	
1.5						0.4	6400	78
2							4800	78
3						0.5	2750	78
4						0.6	1900	78

English

Material Thickness	Current	Torch-to-Work Distance	Initial Pierce Height		Pierce Delay Time	Recommended		
						Cut Speed	Voltage	
	A	inches	inches	%	seconds	ipm	Volts	
26GA	40	0.06	0.09	150	0.0	325	78	
24GA						325	78	
22GA						325	78	
20GA	45				0.1	325	78	
18GA						0.2	325	78
16GA							0.4	250
14GA						200		78
12GA						0.5		120
10GA	95	78						

OPERATION

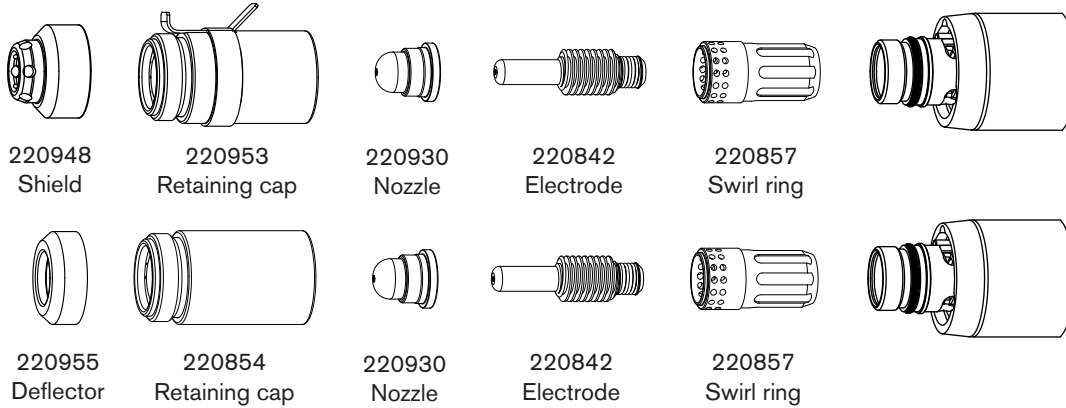

FineCut Stainless Steel

Metric

Material Thickness	Current	Torch-to-Work Distance	Initial Pierce Height		Pierce Delay Time	Recommended		
						Cut Speed	Voltage	
mm	A	mm	mm	%	seconds	(mm/min)	Volts	
0.5	40	0.5	2.0	400	0	8250	68	
0.6						8250	68	
0.8						8250	68	
1	45				0.15	8250	68	
1.5						0.4	6150	70
2							4800	71
3						0.5	2550	80
4						0.6	1050	80

English

Material Thickness	Current	Torch-to-Work Distance	Initial Pierce Height		Pierce Delay Time	Recommended		
						Cut Speed	Voltage	
	A	inches	inches	%	seconds	ipm	Volts	
26GA	40	0.02	0.08	400	0.0	325	68	
24GA						325	68	
22GA					0.1	325	68	
20GA						325	68	
18GA	45				0.2	325	68	
16GA						0.4	240	70
14GA							200	70
12GA						0.5	120	80
10GA		0.6	75	80				

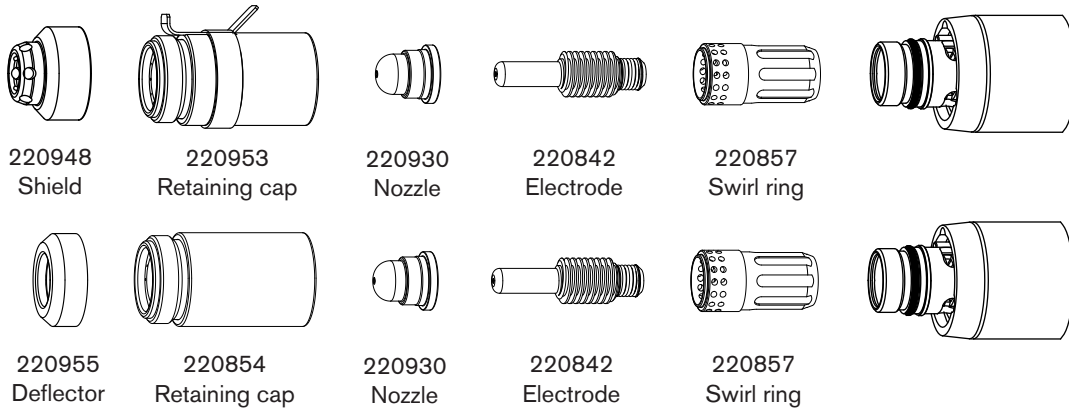

**Low Speed FineCut
Mild Steel**

Metric

Material Thickness	Current	Torch-to-Work Distance	Initial Pierce Height		Pierce Delay Time	Recommended		
						Cut Speed	Voltage	
mm	A	mm	mm	%	seconds	(mm/min)	Volts	
0.5	30	1.5	2.25	150	0	3800	69	
0.6						3800	68	
0.8					0.1	3800	70	
1 *	0.2					3800	72	
1.5 *						3800	75	
2	45				0.4	3700	76	
3						0.5	2750	78
4							0.6	1900

English

Material Thickness	Current	Torch-to-Work Distance	Initial Pierce Height		Pierce Delay Time	Recommended	
						Cut Speed	Voltage
	A	inches	inches	%	seconds	ipm	Volts
26GA	30	0.06	0.09	150	0.0	150	70
24GA						150	68
22GA					0.1	150	70
20GA						150	71
18GA *	40				0.2	150	73
16GA *						0.4	150
14GA	45				0.5		150
12GA						120	78
10GA		95	78				

Note: *Not a dross-free cut.

OPERATION

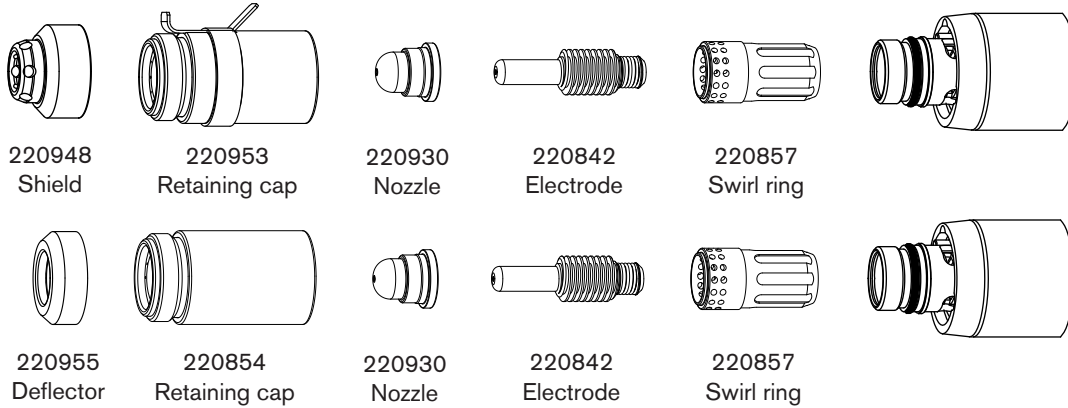

Low Speed FineCut Stainless Steel

Metric

Material Thickness	Current	Torch-to-Work Distance	Initial Pierce Height		Pierce Delay Time	Recommended		
						Cut Speed	Voltage	
mm	A	mm	mm	%	seconds	(mm/min)	Volts	
0.5	30	0.5	2.0	400	0	3800	69	
0.6						3800	69	
0.8						3800	69	
1	40				0.1	3800	69	
1.5						0.4	2900	69
2							2750	69
3	45				0.5	2550	80	
4						1050	80	

English

Material Thickness		Torch-to-Work Distance	Initial Pierce Height		Pierce Delay Time	Recommended		
						Cut Speed	Voltage	
	A	inches	inches	%	seconds	ipm	Volts	
26GA	30	0.02	0.08	400	0.0	150	69	
24GA						150	69	
22GA					0.1	150	69	
20GA						150	69	
18GA	40				0.2	145	69	
16GA						0.4	115	69
14GA							110	69
12GA	45				0.5	120	80	
10GA		0.6	75	80				

Using the hand torch



WARNING
INSTANT-ON TORCHES
PLASMA ARC CAN CAUSE INJURY AND BURNS

Plasma arc comes on immediately when the torch trigger is activated.
The plasma arc will cut quickly through gloves and skin.

- Wear correct and appropriate protective equipment.
- Keep away from the torch tip.
- Do not hold the workpiece and keep your hands clear of the cutting path.
- Never point the torch toward yourself or others.

Operate the safety trigger

The hand torches are equipped with a safety trigger to prevent accidental firings. When you are ready to use the torch, flip the trigger's safety cover forward (toward the torch head) and press the red torch trigger as show below.

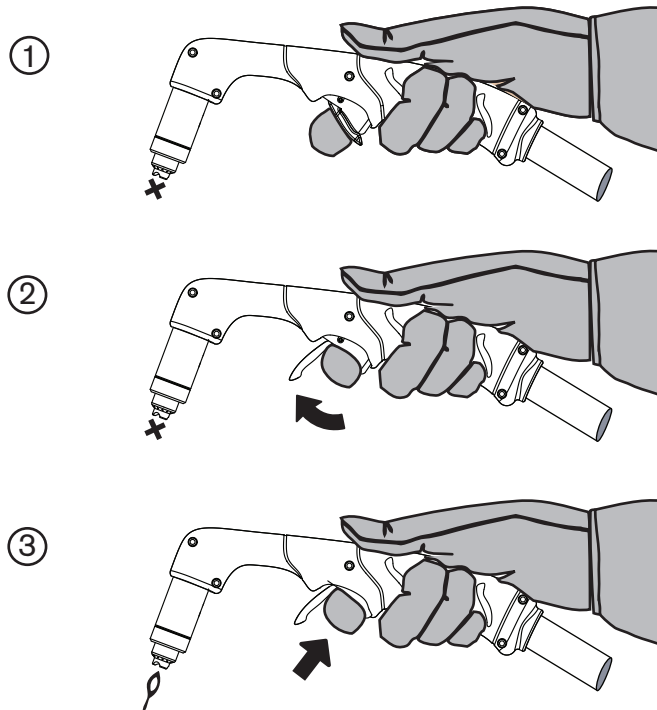

Hand torch cutting hints

- Drag the torch tip lightly along the workpiece to maintain a steady cut.
- While cutting, make sure that sparks exit from the bottom of the workpiece. The sparks should lag slightly behind the torch as you cut (15° — 30° angle from vertical).
- If sparks spray up from the workpiece, move the torch more slowly, or set the output current higher.

- With hand torches, hold the torch nozzle perpendicular to the workpiece so that the nozzle is at a 90° angle to the cutting surface. Observe the cutting arc as the torch cuts.

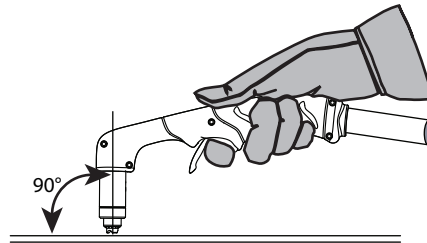

- If you fire the torch unnecessarily, you will shorten the life of the nozzle and electrode.

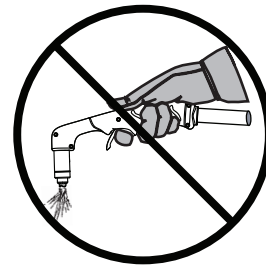

- Pulling, or dragging, the torch along the cut is easier than pushing the torch.
- For straight-line cuts, use a straight edge as a guide. To cut circles, use a template or a radius cutter attachment (a circle cutting guide). See Section 4, *Maintenance and Parts*, for part numbers for the Hypertherm plasma cutting guides for cutting circles and making bevel cuts.

Start a cut from the edge of the workpiece

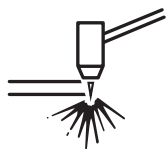

1. With the work clamp attached to the workpiece, hold the torch nozzle perpendicular (90°) to the edge of the workpiece.



2. Press the torch's trigger to start the arc. Pause at the edge until the arc has cut completely through the workpiece.



3. Drag the torch tip lightly across the workpiece to proceed with the cut. Maintain a steady, even pace.



OPERATION

Pierce a workpiece

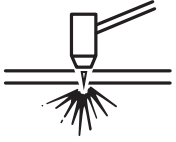

WARNING

SPARKS AND HOT METAL CAN INJURE EYES AND BURN SKIN. When firing the torch at an angle, sparks and hot metal will spray out from the nozzle. Point the torch away from yourself and others.

1. With the work clamp attached to the workpiece, hold the torch at an approximate 30° angle to the workpiece with the torch tip within 1.5 mm (1/16 inch) of the workpiece before firing the torch.
2. Fire the torch while still at an angle to the workpiece. Slowly rotate the torch to a perpendicular (90°) position.
3. Hold the torch in place while continuing to press the trigger. When sparks exit below the workpiece, the arc has pierced the material.
4. When the pierce is complete, drag the nozzle lightly along the workpiece to proceed with the cut.



Gouge a workpiece



		WARNING
<p>SPARKS AND HOT METAL CAN INJURE EYES AND BURN SKIN. When firing the torch at an angle, sparks and hot metal will spray out from the nozzle. Point the torch away from yourself and others.</p>		

1. Hold the torch so that the torch tip is within 1.5 mm (1/16 inch) from the workpiece before firing the torch.

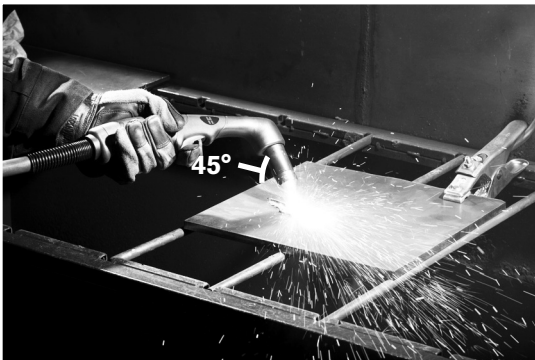

2. Hold the torch at a 45° angle to the workpiece with a small gap between the torch tip and the workpiece. Press the trigger to obtain a pilot arc. Transfer the arc to the work piece.



3. Maintain an approximate 45° angle to the workpiece as you feed into the gouge. Push the plasma arc in the direction of the gouge you want to create. Keep a small distance between the torch tip and the molten metal to avoid reducing consumable life or damaging the torch.

Changing the torch's angle changes the dimensions of the gouge.

General guidelines for gouging

The following actions have the stated effects on the gouge profile:

- **Increasing the speed** of the torch will **decrease width** and **decrease depth**.
- **Decreasing the speed** of the torch will **increase width** and **increase depth**.
- **Increasing the standoff** of the torch will **increase width** and **decrease depth**.
- **Decreasing the standoff** of the torch will **decrease width** and **increase depth**.
- **Increasing the angle** of the torch (more vertical) will **decrease width** and **increase depth**.
- **Decreasing the angle** of the torch (less vertical) will **increase width** and **decrease depth**.
- **Increasing the current** of the power supply will **increase width** and **increase depth**.
- **Decreasing the current** of the power supply will **decrease width** and **decrease depth**.

Common hand-cutting faults

The torch does not cut completely through the workpiece. The causes can be:

- The cut speed is too fast.
- The consumables are worn.
- The metal being cut is too thick for the selected amperage.
- Gouging consumables are installed instead of drag-cutting consumables.
- The work clamp is not attached properly to the workpiece.
- The gas pressure or gas flow rate is too low.

Cut quality is poor. The causes can be:

- The metal being cut is too thick for the amperage.
- The wrong consumables are being used (gouging consumables are installed instead of drag-cutting consumables, for example).
- You are moving the torch too quickly or too slowly.

The arc sputters and consumables life is shorter than expected. The cause can be:

- Moisture in the gas supply.
- Incorrect gas pressure.
- Consumables incorrectly installed.

Using the machine torch

Since the Powermax with a machine torch can be used with a wide variety of cutting tables, track burners, pipe bevelers, and so on, you will need to refer to the manufacturer's instructions for specifics on operating the machine torch in your configuration. However, the information in the following sections will help you optimize cut quality and maximize consumable life.

Ensure the torch and table are set up correctly

- Use a square to align the torch at right angles to the workpiece in two dimensions.
- The torch may travel more smoothly if you clean, check and “tune” the cutting table's rails and drive system. Unsteady machine motion can cause a regular, wavy pattern on the cut surface.
- Ensure that the torch does not touch the workpiece during cutting. Contact with the workpiece can damage the shield and nozzle and affect the cut surface.

Understand and optimize cut quality

There are several factors to consider in cut quality:

- Cut angle — The degree of angularity of the cut edge.
- Dross — The molten material that solidifies on the top or bottom of the workpiece.
- Straightness of the cut surface — The cut surface can be concave or convex.

The following sections explain how these factors can affect cut quality.

Cut or bevel angle

- A positive cut angle, or bevel, results when more material is removed from the top of the cut than from the bottom.
- A negative cut angle results when more material is removed from the bottom of the cut.

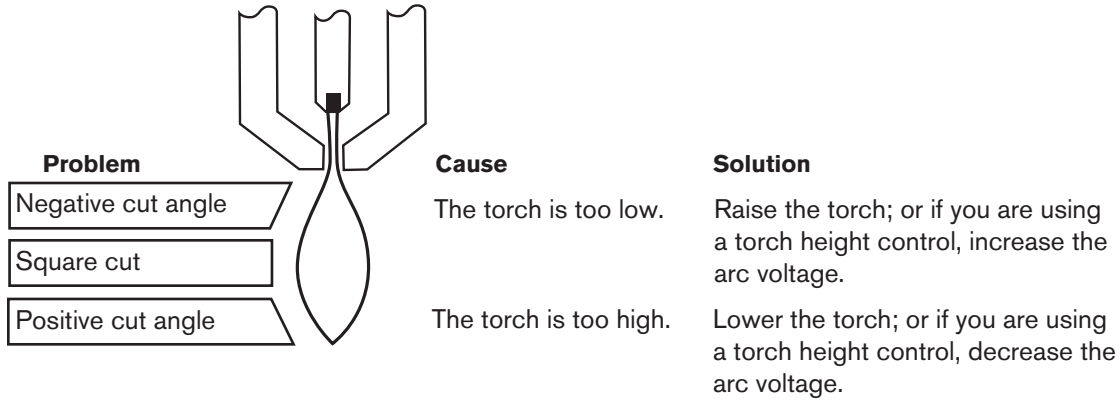

Note: The squarest cut angle will be on the *right* side with respect to the forward motion of the torch. The left side will always have some degree of bevel.

To determine whether a cut-angle problem is being caused by the plasma system or the drive system, make a test cut and measure the angle of each side. Next, rotate the torch 90° in its holder and repeat the process. If the angles are the same in both tests, the problem is in the drive system.

If a cut-angle problem persists after “mechanical causes” have been eliminated (see “Ensure the torch and table are set up correctly” on the previous page), check the torch-to-work distance, especially if the cut angles are all positive or all negative. Also consider the material being cut: if the metal is magnetized or hardened, you are more likely to experience cut angle problems.

Dross

Some amount of dross will always be present when cutting with air plasma. However, you can minimize the amount and type of dross by adjusting your system correctly for your application.

Excess dross appears on the top edge of both pieces of the plate when the torch is too low (or voltage is too low when using a torch height control). Adjust the torch or adjust the voltage in small increments (5 volts or less) until the dross is reduced.

Low-speed dross forms when the torch's cutting speed is too slow and the arc angles ahead. It forms as a heavy, bubbly deposit at the bottom of the cut and can be removed easily. Increase the speed to reduce this type of dross.



High-speed dross forms when the cutting speed is too fast and the arc angles behind. It forms as a thin, linear bead of solid metal attached very close to the cut. It is more firmly attached to the bottom of the cut than at low speed and is difficult to remove. To reduce high-speed dross:

- Decrease the cutting speed.
- Decrease the torch-to-work distance.

Note: Dross is more likely to form on warm or hot metal than on cool metal. For example, the first cut in a series of cuts usually produces the least dross. As the workpiece heats up, more dross can accumulate on subsequent cuts.

Worn or damaged consumables may produce excess dross.

Straightness of the cut surface

	<p>A typical plasma cut surface is slightly concave.</p> <p>The cut surface may become more concave, or convex. Correct torch height is required to keep the cut surface acceptably close to straight. Worn consumables also affect the straightness of the cut.</p>
	<p>A strongly concave cut surface occurs when the torch-to-work distance is too low. Increase the torch-to-work distance to straighten the cut surface.</p>
	<p>A convex cut surface occurs when the torch-to-work distance is too great or the cutting current is too high. First, try lowering the torch, then reduce the cutting current.</p>

To pierce a workpiece using the machine torch

As with the hand torch, you can start a cut with the machine torch at the edge of the workpiece or by piercing the workpiece. Piercing will result in a shorter consumable life than with edge starts.

The pierce delay must be sufficiently long that the arc can pierce the material before the torch moves, but not so long that the arc “wanders” while trying to find the edge of a large hole.

When piercing maximum thicknesses, the ring of dross that forms during the pierce may become high enough to contact the torch when the torch begins to move after the pierce is complete. Remove the dross if the torch will contact it during the cut.

Common machine-cutting faults

The torch's pilot arc will initiate, but will not transfer. Causes can be:

- The work cable is not making good contact with the cutting table or the cutting table is not making good contact with the workpiece.
- The torch-to-work distance is too large.

The workpiece is not totally penetrated, and there is excessive sparking on the top of the workpiece. Causes can be:

- The consumables are worn and need to be replaced. For optimized performance in a mechanized application, replace the nozzle and the electrode together.
- The work cable is not making good contact with the cutting table or the cutting table is not making good contact with the workpiece.
- The current (amperage) is set too low. See “Using the cut charts” on page 3-2 for more information.
- The cut speed is too high. See “Using the cut charts” on page 3-2 for more information.
- The metal being cut exceeds the maximum capacity for the selected amperage.

Dross forms on the bottom of the cut. Causes can be:

- The consumables are worn and need to be replaced. For optimized performance in a mechanized application, replace the nozzle and the electrode together.
- The cutting speed is not correct. See “Using the cut charts” on page 3-2 for more information.
- The current (amperage) is set too low. See “Using the cut charts” on page 3-2 for more information.

The cut angle is not square. Causes can be:

- The torch is not square to the workpiece.
- The consumables are worn and need to be replaced. For optimized performance in a mechanized application, replace the nozzle and the electrode together.
- The direction of the torch travel is incorrect. The high-quality cut is always on the right with respect to the forward motion of the torch.
- The distance between the torch and the workpiece is not correct.
- The cutting speed is not correct. See "Using the cut charts" on page 3-2 for more information.

The consumables' life is shortened. Causes can be:



- The arc current, arc voltage, travel speed, and other variables are not set as recommended in the cut charts.
- Firing the arc in the air (beginning or ending the cut off of the plate surface). Starting at the edge is acceptable as long as the arc makes contact with the workpiece when started.
- Starting a pierce with an incorrect torch height. Refer to the cut charts for the specific initial pierce height.

Section 4

Maintenance and parts

Perform routine maintenance	4-2
Inspect the consumables	4-3
Hand torch replacement parts – Duramax HRT ₂	4-4
Machine torch replacement parts – Duramax MRT ₂	4-5
Accessory parts.....	4-6

Perform routine maintenance

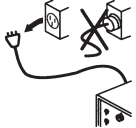
		<p>DANGER ELECTRIC SHOCK CAN KILL</p>
	<p>Disconnect the electrical power before you perform any maintenance. All work that requires removal of the power supply cover must be performed by a qualified technician.</p>	

Every use:

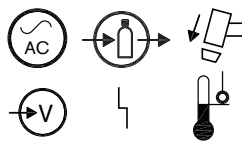

Check indicator lights and fault icons.
Correct any fault conditions.

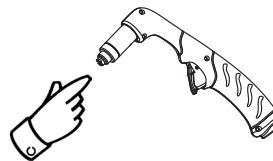

Inspect the consumables for proper installation and wear.

Every 3 months:



Replace any damaged labels.

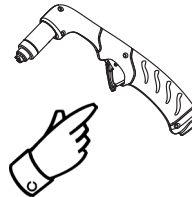

Inspect the trigger for damage. Inspect the torch body for cracks and exposed wires. Replace any damaged parts.



Inspect the power cord and plug. Replace if damaged.



Inspect the torch lead. Replace if damaged.

Every 6 months:

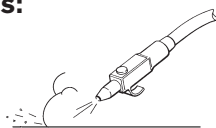



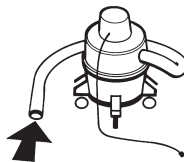

Or

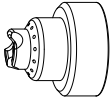

Clean the inside of the power supply with compressed air or a vacuum.

Inspect the consumables

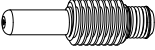
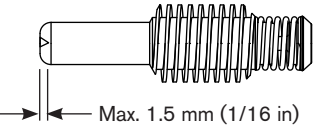
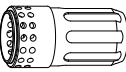
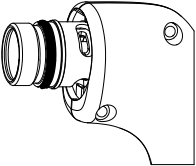
Part		Inspect	Action
	Shield or deflector	The center hole for roundness. The gap between the shield and the nozzle for accumulated debris.	Replace the shield if the hole is no longer round. Remove the shield and clean away any material.
	Nozzle	The center hole for roundness.  Good  Worn	Replace nozzle if the center hole is not round.
	Electrode	 Max. 1.5 mm (1/16 in)	Replace electrode if the surface is worn or the pit depth is greater than 1/16 inch (1.6 mm) deep.
	Swirl ring	The surface inside the swirl ring for damage or wear and the gas holes for blockages.	Replace swirl ring if the surface is damaged or worn or any of the gas holes are blocked.
	Torch o-ring	The surface for damage, wear, or a lack of lubrication.	If the o-ring is dry, lubricate it and the threads with a thin layer of silicone lubricant. If the o-ring is worn or damaged, replace it.

Hand torch replacement parts – Duramax HRT₂

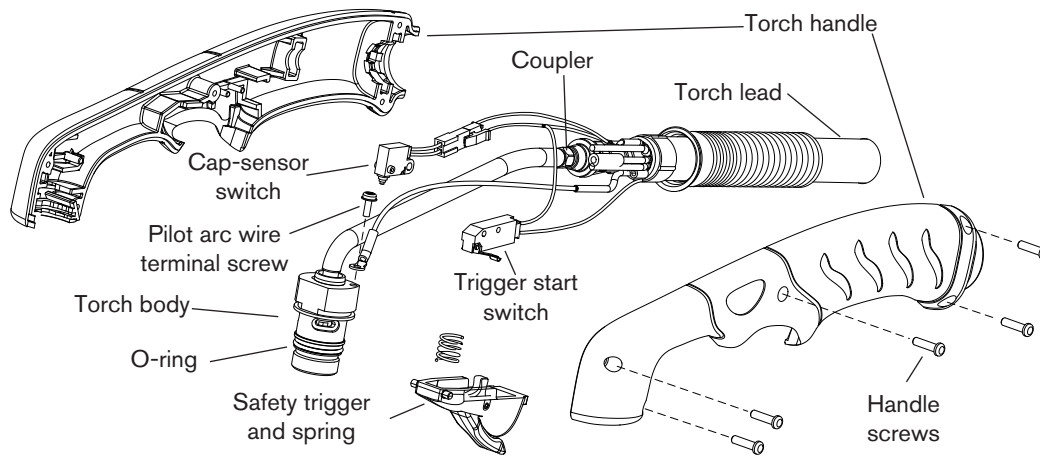

The HRT₂ torch assembly can be replaced, or individual component parts can be replaced. The HRT₂ torch assembly includes a variety of Duramax consumables.

Part number	Description
005252	Trigger start switch
058519	O-ring
075504	Pilot arc wire terminal screw
075714	Handle screws, #4 x 1/2 slotted TORX pan head, S/B
128926*	Kit: Quick disconnect repair
228954	Kit: Duramax 75°/HRT ₂ torch handle replacement
228719	Kit: Duramax 75°/HRT ₂ cap-sensor switch replacement
228721	Kit: Safety trigger with spring replacement
228924*	Kit: HRT ₂ lead replacement, 7.6 m (25 ft)
228925*	Kit: HRT ₂ lead replacement, 15.2 m (50 ft)
228926**	Kit: HRT ₂ lead replacement, 7.6 m (25 ft) – without quick disconnect
228927**	Kit: HRT ₂ lead replacement, 15.2 m (50 ft) – without quick disconnect
228916*	Kit: HRT ₂ torch assembly with 7.6 m (25 ft) lead
228917*	Kit: HRT ₂ torch assembly with 15.2 m (50 ft) lead
228918**	Kit: HRT ₂ torch assembly with 7.6 m (25 ft) lead – without quick disconnect
228919**	Kit: HRT ₂ torch assembly with 15.2 m (50 ft) lead – without quick disconnect
228950	Kit: HRT ₂ torch main body replacement, coupler with 12.7 mm (1/2 in.) threads

* For use with Powermax600, Powermax800, Powermax900, MAX42, and MAX43 CSA systems.

** For use with Powermax600 CE systems.

Machine torch replacement parts – Duramax MRT₂

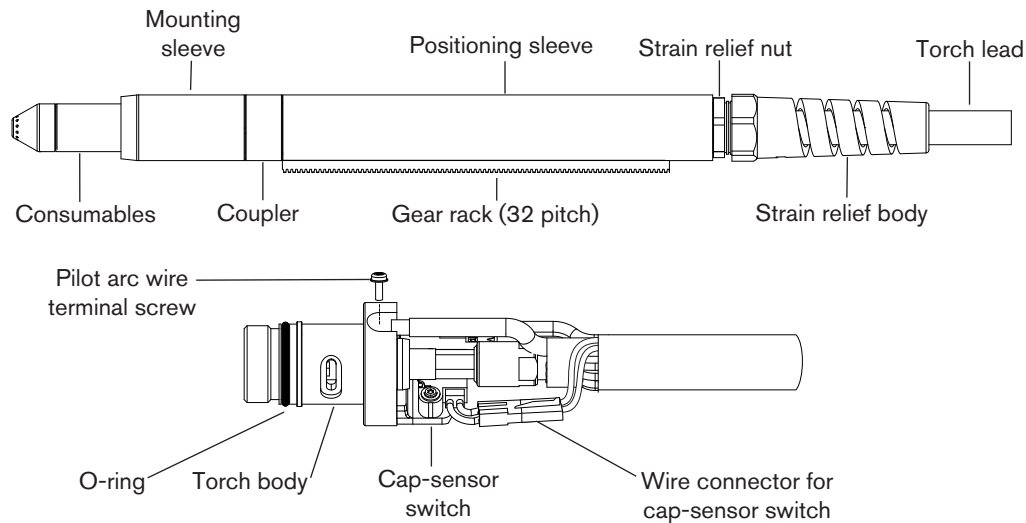

The MRT₂ torch assembly can be replaced, or individual component parts can be replaced. The MRT₂ torch assembly includes a variety of Duramax consumables.

Part number	Description
058519	O-ring
075504	Pilot arc wire terminal screw
128926*	Kit: Quick disconnect repair
228720	Kit: Cap-sensor switch replacement
228735	Kit: M65/M65m/M85/M85m/MRT ₂ front mounting sleeve
228736	Kit: M65/M65m/M85/M85m/MRT ₂ adapter ring (coupler)
228737	Kit: M65/M85/MRT ₂ positioning sleeve
228738	Kit: M65/M85/MRT ₂ removable gear rack
228928*	Kit: MRT ₂ lead replacement, 7.6 m (25 ft)
228929*	Kit: MRT ₂ lead replacement, 15.2 m (50 ft)
228930**	Kit: MRT ₂ lead replacement, 7.6 m (25 ft) – without quick disconnect
228931**	Kit: MRT ₂ lead replacement, 15.2 m (50 ft) – without quick disconnect
228920*	Kit: MRT ₂ torch assembly with 7.6 m (25 ft) lead
228921*	Kit: MRT ₂ torch assembly with 15.2 m (50 ft) lead
228922**	Kit: MRT ₂ torch assembly with 7.6 m (25 ft) lead – without quick disconnect
228923**	Kit: MRT ₂ torch assembly with 15.2 m (50 ft) lead – without quick disconnect
228793	Kit: MRT ₂ torch main body replacement

* For use with Powermax600, Powermax800, Powermax900, MAX42, and MAX43 CSA systems.

** For use with Powermax600 CE systems.

Accessory parts

Part number	Description
024548	Leather torch sheathing, 7.5 m (25 ft)
127102	Basic plasma (circles and lines) cutting guide
027668	Deluxe plasma (circles and lines) cutting guide