

**Strong  
Hand  
Tools**®

**Better Tools. Better Price.**

**2011 Catalog**

Innovative Fit-Up Tools:  
Clamps, Magnets, Pliers,  
and Welding Tables.

Fixture more  
efficiently with  
economical,  
quick-acting  
Strong Hand Tools.®



[www.stronghandtools.com](http://www.stronghandtools.com)



## Better Tools. Better Price.®

Innovative Fit-Up Tools: Clamps, Magnets, Pliers, and Welding Tables.

### Strong Hand Tools® Features and Benefits

- » Strong Hand Tools® are multi-functional, serving more than just one application.
- » All of our Clamps are "Quick Acting" for the fastest set-up.
- » Strong Hand Tools® are modular, with interchangeable accessories, so you get the most for Your Money.
- » All of our tools are economically-priced to fit Your Budget.
- » Our products can be purchased through our distributors worldwide.

### Save Time & Money

Strong Hand Tools® are designed to reduce set-up time in all of your workholding applications. Developed by customer demand, and tested in the field by professional craftsmen, Strong Hand Tools® provide an easier, safer, faster way to complete your work. Plus, Strong Hand Tools® are always affordably priced, so you save money when you buy them, and when you use them.

### Mission Statement

At Strong Hand Tools® we remain dedicated to designing the most innovative, time-saving, money-saving workholding tools to improve your efficiency, productivity, competitiveness, and profitability.

### Contact Information

**Toll Free** 800.989.5244  
**Phone** 562.949.8625  
**Fax** 562.949.4875

**Web**  
[www.stronghandtools.com](http://www.stronghandtools.com)

**E-Mail**  
[sales@stronghandtools.com](mailto:sales@stronghandtools.com)

**Headquarters**  
 7141 Paramount Blvd.  
 Pico Rivera, CA 90660 U.S.A.









Corporate Headquarters



Manufacturing Facility



# Table of Contents

<b>NEW</b>		<b>UTILITY SLIDING ARM CLAMPS</b>													
<b>1</b>	<b>Clamping Kits</b>	<b>2</b>	<b>4-IN-1</b>	<b>3-4</b>	<b>Utility Clamps</b>	<b>5</b>	<b>Ratchet</b>	<b>5</b>	<b>MagSpring™</b>	<b>6</b>	<b>EZ Grip</b>	<b>6</b>	<b>Straight Handle</b>		
															
<b>ADJUST-O™ MAGNET GROUP &amp; OTHER INNOVATIVE MAGNETS</b>															
<b>7</b>	<b>Squares</b>	<b>7</b>	<b>Dual Switch</b>	<b>8</b>	<b>Multi-Angle</b>	<b>8</b>	<b>Standard</b>	<b>8</b>	<b>Mini</b>	<b>9</b>	<b>MagTab™</b>	<b>9</b>	<b>Mag V-Pads</b>	<b>9</b>	<b>Snake</b>
															
<b>MAGNETS &amp; LEVELS</b>						<b>IMPROVED LOCKING PLIERS</b>									
<b>10</b>	<b>Corner Magnet</b>	<b>10</b>	<b>Mag-Levels</b>	<b>11</b>	<b>Regular</b>	<b>11</b>	<b>Multi-Purpose</b>	<b>11</b>	<b>Long Reach</b>	<b>12</b>	<b>Pipe</b>				
															
<b>IMPROVED LOCKING PLIERS</b>						<b>VICES</b>									
<b>13</b>	<b>Chain</b>	<b>14</b>	<b>Table Mount</b>	<b>14</b>	<b>Expand-O</b>	<b>15</b>	<b>Welder's Angle Clamps</b>	<b>16</b>	<b>Portable MagVises</b>	<b>16</b>	<b>90° Tru-AngL</b>				
															
<b>HANDLELESS TAPPER</b>			<b>ANGLE JOINING TOOLS</b>			<b>GROUNDING MAGNETS &amp; CLAMPS</b>									
<b>13</b>	<b>Handi-Hammer</b>	<b>17</b>	<b>JointMaster™ Series</b>	<b>18</b>	<b>PowerBase™ Magnet</b>	<b>18</b>	<b>Ground Hog™ Clamps</b>								
															
<b>MISC. CLAMPS</b>						<b>WELDING TABLES</b>									
<b>19</b>	<b>Platen Clamps</b>	<b>20</b>	<b>Shark Clamps</b>	<b>20</b>	<b>Side Clamps</b>	<b>20</b>	<b>Half Clamps</b>	<b>21</b>	<b>Nomad™</b>	<b>21</b>	<b>Connector Plate</b>				
															
<b>TOGGLE CLAMPS</b>						<b>REPLACEMENT PARTS</b>			<b>STANDARD MACHINE PARTS</b>						
<b>22</b>	<b>Twin Slot</b>	<b>23</b>	<b>Vertical</b>	<b>23</b>	<b>Horizontal</b>	<b>24</b>	<b>Push/Pull</b>	<b>24</b>	<b>Latch</b>	<b>25-26</b>	<b>Accessories</b>	<b>28</b>	<b>Valtra Components</b>		
															

# Strong Hand Tools Clamping Kits

Receive 10% off list price on the clamping kits and receive a free gift!

Having the right tools on hand makes every job easier to complete. These kits contain the most essential tools for clamping, holding, and positioning steel. Efficiency + Cost Savings are an unbeatable combination.

## Utility Clamp Kit #1

Part No. UDK4-5

Kit contents:

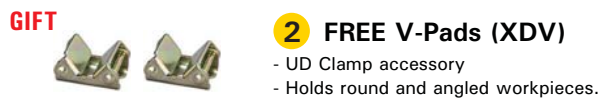
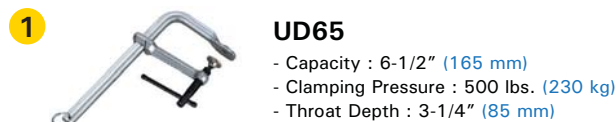
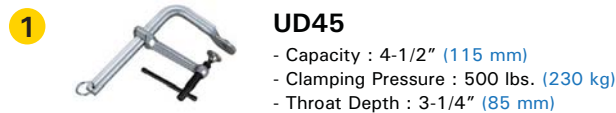

## Adjust-O Magnet Kit

Part No. MK4-4

Kit contents:

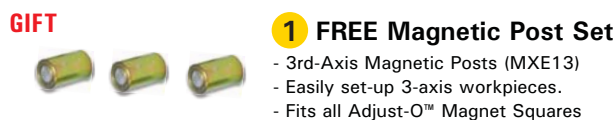
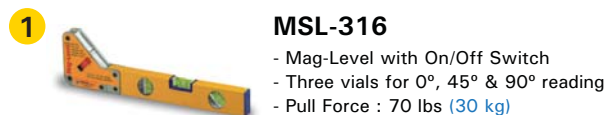
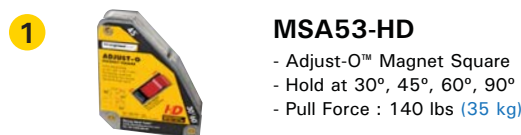
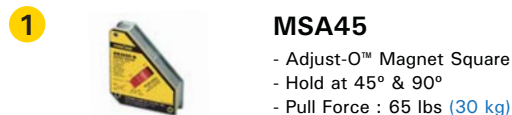

## Utility Clamp Kit #2

Part No. UFK4-4

Kit contents:

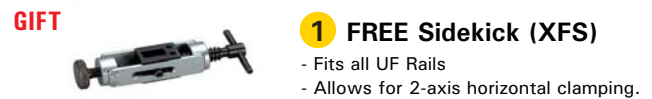
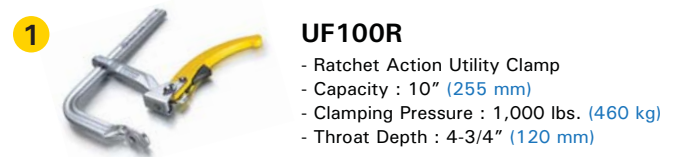
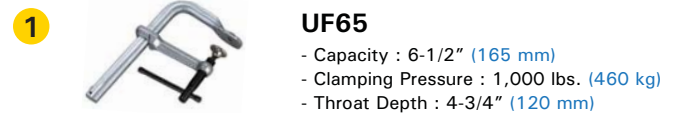

## Magnetic Clamping Kit

Part No. TSK104

Kit contents:

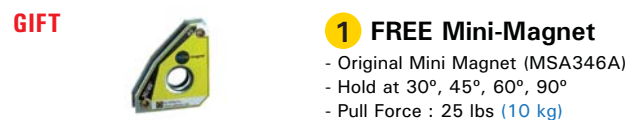
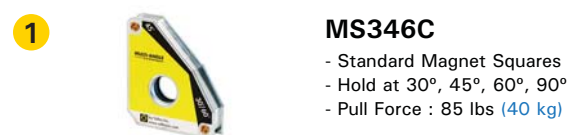

All items can be purchased separately.

# 4-IN-1™ Utility Clamping System

**BEST SELLERS**

The most versatile Sliding Arm Clamps in the market.

The strong, economical 4-IN-1 Utility Clamps adapt to serve four different applications.

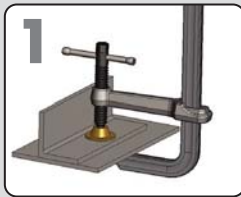

**1 Standard**  
Sliding Arm Clamps are 10x faster than a C-Clamp!



**2 Pipe**  
Add the exclusive V-Pad to create a Pipe Clamp!

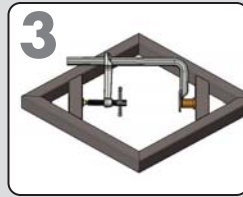

**3 Spreader**  
Reverse the clamp arm and create a Spreader Clamp.

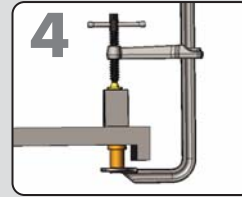

**4 Step-Over**  
Add the Extender Block to create a Step-Over Clamp.

The 4-IN-1 Clamp Kit comes complete with the V-Pad and Extender Block accessories.



Extender Block V-Pad



**Spring Loaded Stop** (UF, UG, UM)  
Allows removal and reversal of the clamp arm for spreading.  
- UD models, remove keyring.  
- UP models, remove screw.



**Tapped Hole**  
For attaching accessories such as a V-Pad or Extender Block.



“  
*I finally upgraded from my old C-Clamp to a 4-in-1 Clamp and I was amazed at how much set-up time I saved.*”

- Scott M.

All Strong Hand Tools® Utility Clamps are made of high quality heat treated steel and nickel/chrome plated for strength and durability.

Part No.	Capacity	Throat Depth	Clamping Pressure	Pads	Rail Size	Tapped Hole	Weight
UD45-C3 UD45M-C3	4-1/2" 115 mm	3-1/4" 80 mm	500 lbs 230 kg	Standard	5/8" x 5/16" 16 mm x 8	5/16-18 M8	1.3 lbs 0.6 kg
UD65-C3 UD65M-C3	6-1/2" 165 mm	3-1/4" 80 mm	500 lbs 230 kg	Standard	5/8" x 5/16" 16 mm x 8	5/16-18 M8	1.6 lbs 0.7 kg
UF65-C3 UF65M-C3	6-1/2" 165 mm	4-3/4" 120 mm	1,000 lbs 460 kg	Standard	7/8" x 7/16" 22 mm x 11	3/8-16 M10	2.9 lbs 1.3 kg
UG85-C3 UG85M-C3	8-1/2" 215 mm	4-3/4" 120 mm	1,200 lbs 550 kg	Standard	1" x 15/32" 25 mm x 12	3/8-16 M10	4.1 lbs 1.9 kg
UG125-C3 UG125M-C3	12-1/2" 320 mm	4-3/4" 120 mm	1,200 lbs 550 kg	Standard	1" x 15/32" 25 mm x 12	3/8-16 M10	4.5 lbs 2.1 kg
UG1257-C3 UG1257M-C3	12-1/2" 320 mm	<b>DEEP THROAT</b> 7" 180 mm	800 lbs 350 kg	Standard	1" x 15/32" 25 mm x 12	3/8-16 M10	6.5 lbs 2.9 kg
UM85P-C3 UM85PM-C3	8-1/2" 215 mm	5-1/2" 140 mm	2,400 lbs 1,100 kg	Standard	1-3/16" x 9/16" 30 mm x 14	3/8-16 M10	6.6 lbs 3.0 kg
UM105P-C3 UM105PM-C3	10-1/2" 265 mm	5-1/2" 140 mm	2,400 lbs 1,100 kg	Standard	1-3/16" x 9/16" 30 mm x 14	3/8-16 M10	7.4 lbs 3.4 kg
UM125-C3 UM125M-C3	12-1/2" 320 mm	5-1/2" 140 mm	2,400 lbs 1,100 kg	Heavy Duty	1-3/16" x 9/16" 30 mm x 14	3/8-16 M10	7.6 lbs 3.5 kg
UM165-C3 UM165M-C3	16-1/2" 420 mm	5-1/2" 140 mm	2,400 lbs 1,100 kg	Heavy Duty	1-3/16" x 9/16" 30 mm x 14	3/8-16 M10	8.7 lbs 4.0 kg
UM205-C3 UM205M-C3	20-1/2" 520 mm	5-1/2" 140 mm	2,400 lbs 1,100 kg	Heavy Duty	1-3/16" x 9/16" 30 mm x 14	3/8-16 M10	9.8 lbs 4.5 kg
UP205-C3 UP205M-C3	20-1/2" 520 mm	<b>DEEP THROAT</b> 7" 180 mm	4,800 lbs 2,200 kg	Heavy Duty	1-9/16" x 3/4" 40 mm x 19	3/8-16 M10	16.1 lbs 7.3 kg

# Utility Clamps

## Light Duty Series and J-Clamp Step-Over Series

### Light Duty



• **Clamping Pressure:**  
500 -1,200 lbs. (230 - 550 kg)

• **Throat Depth:**  
3-1/4" - 7" (83 - 178 mm)

Standard Pads

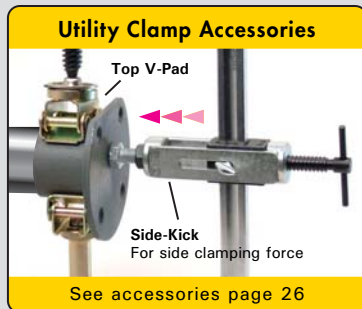

Part No.	Capacity	Throat Depth	Clamping Pressure	Rail Size	Tapped Hole	Weight
UD45 UD45M	4-1/2" 115 mm	3-1/4" 85 mm	500 lbs 230 kg	5/8" x 5/16" 16 mm x 8	5/16-18 M8	1.0 lbs 0.4 kg
UD65 UD65M	6-1/2" 165 mm	3-1/4" 85 mm	500 lbs 230 kg	5/8" x 5/16" 16 mm x 8	5/16-18 M8	1.1 lbs 0.5 kg
UD85 UD85M	8-1/2" 215 mm	3-1/4" 85 mm	500 lbs 230 kg	5/8" x 5/16" 16 mm x 8	5/16-18 M8	1.2 lbs 0.6 kg
UE85 UE85M	8-1/2" 215 mm	4" 100 mm	850 lbs 390 kg	25/32" x 3/8" 20 mm x 10	3/8-16 M10	2.3 lbs 1.1 kg
UE125 UE125M	12-1/2" 320 mm	4" 100 mm	850 lbs 390 kg	25/32" x 3/8" 20 mm x 10	3/8-16 M10	2.5 lbs 1.2 kg
UE165 UE165M	16-1/2" 420 mm	4" 100 mm	850 lbs 390 kg	25/32" x 3/8" 20 mm x 10	3/8-16 M10	2.8 lbs 1.3 kg
UE205 UE205M	20-1/2" 520 mm	4" 100 mm	850 lbs 390 kg	25/32" x 3/8" 20 mm x 10	3/8-16 M10	3.0 lbs 1.4 kg
UE245 UE245M	24-1/2" 620 mm	4" 100 mm	850 lbs 390 kg	25/32" x 3/8" 20 mm x 10	3/8-16 M10	3.4 lbs 1.6 kg
UF65 UF65M	6-1/2" 165 mm	4-3/4" 120 mm	1,000 lbs 460 kg	7/8" x 7/16" 22 mm x 11	3/8-16 M10	2.4 lbs 1.1 kg
UF100 UF100M	10" 255 mm	4-3/4" 120 mm	1,000 lbs 460 kg	7/8" x 7/16" 22 mm x 11	3/8-16 M10	2.8 lbs 1.3 kg
UG85 UG85M	8-1/2" 215 mm	4-3/4" 120 mm	1,200 lbs 550 kg	1" x 15/32" 25 mm x 12	3/8-16 M10	3.6 lbs 1.6 kg
UG125 UG125M	12-1/2" 320 mm	4-3/4" 120 mm	1,200 lbs 550 kg	1" x 15/32" 25 mm x 12	3/8-16 M10	4.0 lbs 1.8 kg
UG205 UG205M	20-1/2" 520 mm	4-3/4" 120 mm	1,200 lbs 550 kg	1" x 15/32" 25 mm x 12	3/8-16 M10	4.8 lbs 2.2 kg
UG1257 UG1257M	12-1/2" 320 mm	DEEP THROAT 7" 180 mm	800 lbs 350 kg	1" x 15/32" 25 mm x 12	3/8-16 M10	6.0 lbs 2.7 kg
UG1657 UG1657M	16-1/2" 420 mm	DEEP THROAT 7" 180 mm	800 lbs 350 kg	1" x 15/32" 25 mm x 12	3/8-16 M10	6.5 lbs 3.0 kg
UG2057 UG2057M	20-1/2" 520 mm	DEEP THROAT 7" 180 mm	800 lbs 350 kg	1" x 15/32" 25 mm x 12	3/8-16 M10	7.0 lbs 3.2 kg

### J-Clamp Step-Over Series



Part No.	Capacity	Throat Depth (Return)	Clamping Pressure	Rail Size	Tapped Hole	Weight
UD45J UD45JM	4-1/2" 115 mm	3-1/4" (2) 85 mm (50)	500 lbs 230 kg	5/8" x 5/16" 16 mm x 8	5/16-18 M8	1.2 lbs 0.6 kg
UF100J UF100JM	10" 255 mm	4-3/4" (3") 120 mm (75)	1,000 lbs 460 kg	7/8" x 7/16" 22 mm x 11	3/8-16 M10	3.2 lbs 1.5 kg
UG105J UG105JM	10-1/2" 265 mm	4-3/4" (3") 120 mm (75)	1,200 lbs 550 kg	1" x 15/32" 25 mm x 12	3/8-16 M10	5.0 lbs 2.3 kg
UM125J UM125JM	12-1/2" 320 mm	5-1/2" (4") 140 mm (120)	2,400 lbs 1,100 kg	1-3/16" x 9/16" 30 mm x 14	3/8-16 M10	8.1 lbs 3.7 kg
UM165J UM165JM	16-1/2" 420 mm	5-1/2" (4") 140 mm (120)	2,400 lbs 1,100 kg	1-3/16" x 9/16" 30 mm x 14	3/8-16 M10	8.5 lbs 4.0 kg
UM205J UM205JM	20-1/2" 520 mm	5-1/2" (4") 140 mm (120)	2,400 lbs 1,100 kg	1-3/16" x 9/16" 30 mm x 14	3/8-16 M10	9.2 lbs 4.2 kg

\*UM Models are equipped with heavy duty pads.



# Utility Clamps (cont.)

Create your own 4-IN-1 Kit with the 4-IN-1 Accessory Pack! (See Below)

## Regular Duty



- Clamping Pressure:  
2,400 lbs. (1,100 kg)
- Throat Depth:  
5-1/2" (140 mm)
- ★ Heavy Duty Replaceable Pads

Part No.	Capacity	Throat Depth	Clamping Pressure	Rail Size	Tapped Hole	Weight
UM65 UM65M	6-1/2" 165 mm	5-1/2" 140 mm	2,400 lbs 1,100 kg	1-3/16" x 9/16" 30 mm x 14	3/8-16 M10	5.4 lbs 2.5 kg
UM85 UM85M	8-1/2" 215 mm	5-1/2" 140 mm	2,400 lbs 1,100 kg	1-3/16" x 9/16" 30 mm x 14	3/8-16 M10	5.9 lbs 2.7 kg
UM105 UM105M	10-1/2" 265 mm	5-1/2" 140 mm	2,400 lbs 1,100 kg	1-3/16" x 9/16" 30 mm x 14	3/8-16 M10	6.4 lbs 2.9 kg
UM125 UM125M	12-1/2" 320 mm	5-1/2" 140 mm	2,400 lbs 1,100 kg	1-3/16" x 9/16" 30 mm x 14	3/8-16 M10	7.0 lbs 3.2 kg
UM165 UM165M	16-1/2" 420 mm	5-1/2" 140 mm	2,400 lbs 1,100 kg	1-3/16" x 9/16" 30 mm x 14	3/8-16 M10	7.6 lbs 3.5 kg
UM205 UM205M	20-1/2" 520 mm	5-1/2" 140 mm	2,400 lbs 1,100 kg	1-3/16" x 9/16" 30 mm x 14	3/8-16 M10	8.7 lbs 4.0 kg

## Heavy Duty



- Clamping Pressure:  
4,800 lbs. (2,200 kg)
- Throat Depth:  
7" (180 mm)
- ★ Heavy Duty Replaceable Pads

Part No.	Capacity	Throat Depth	Clamping Pressure	Rail Size	Tapped Hole	Weight
UP125 UP125M	12-1/2" 320 mm	7" 180 mm	4,800 lbs 2,200 kg	1-9/16" x 3/4" 40 mm x 19	3/8-16 M10	12.3 lbs 5.6 kg
UP165 UP165M	16-1/2" 420 mm	7" 180 mm	4,800 lbs 2,200 kg	1-9/16" x 3/4" 40 mm x 19	3/8-16 M10	13.6 lbs 6.2 kg
UP205 UP205M	20-1/2" 520 mm	7" 180 mm	4,800 lbs 2,200 kg	1-9/16" x 3/4" 40 mm x 19	3/8-16 M10	15.0 lbs 6.8 kg
UP245 UP245M	24-1/2" 620 mm	7" 180 mm	4,800 lbs 2,200 kg	1-9/16" x 3/4" 40 mm x 19	3/8-16 M10	16.5 lbs 7.5 kg
UP315 UP315M	31-1/2" 800 mm	7" 180 mm	4,800 lbs 2,200 kg	1-9/16" x 3/4" 40 mm x 19	3/8-16 M10	16.8 lbs 7.6 kg
UP405 UP405M	40-1/2" 1,020 mm	7" 180 mm	4,800 lbs 2,200 kg	1-9/16" x 3/4" 40 mm x 19	3/8-16 M10	22.0 lbs 10.0 kg

## Value Series



- Clamping Pressure:  
2,400 lbs. (1,100 kg)
- Throat Depth:  
5-1/2" (140 mm)
- Standard Pads

Part No.	Capacity	Throat Depth	Clamping Pressure	Rail Size	Tapped Hole	Weight
UM85P UM85PM	8-1/2" 215 mm	5-1/2" 140 mm	2,400 lbs 1,100 kg	1-3/16" x 9/16" 30 mm x 14	3/8-16 M10	5.7 lbs 2.9 kg
UM105P UM105PM	10-1/2" 265 mm	5-1/2" 140 mm	2,400 lbs 1,100 kg	1-3/16" x 9/16" 30 mm x 14	3/8-16 M10	6.3 lbs 3.0 kg
UM125P UM125PM	12-1/2" 320 mm	5-1/2" 140 mm	2,400 lbs 1,100 kg	1-3/16" x 9/16" 30 mm x 14	3/8-16 M10	6.4 lbs 3.1 kg

### 4-IN-1 Accessory Pack (Refer to Accessories Page 26 for more information)

		The 4-IN-1 Kit includes a V-Pad, an Extender Block, and a screw.
Part No.	Description	Weight
XMVB XMVBM	For UM, UP Models (Includes XMV, XMB2)	1.1 lbs 0.5 kg
XFVB XFVBM	For UE, UF, UG Models (Includes XFV, XFB)	0.6 lbs 0.3 kg
XDVB XDVBM	For UD Models (Includes XDV, XDB1)	0.3 lbs 0.1 kg

# Ratchet Action & MagSpring™ Clamps

Quick-Set Clamps for fast, convenient clamping.

## Ratchet Action Utility Clamps

Ratchet mechanism ensures rapid, vibration and torsion resistant clamping.

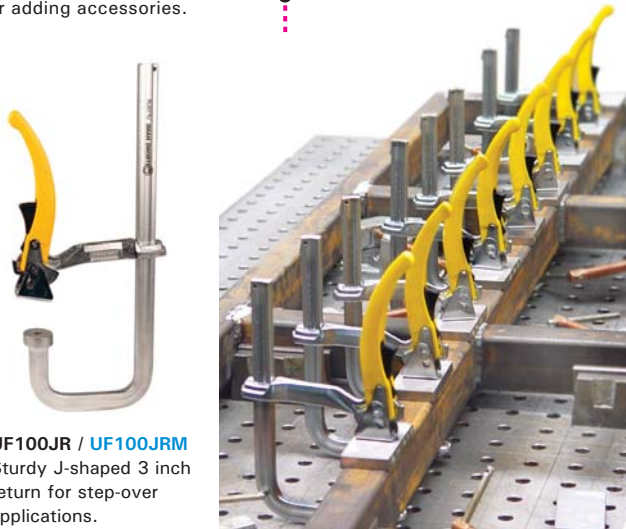
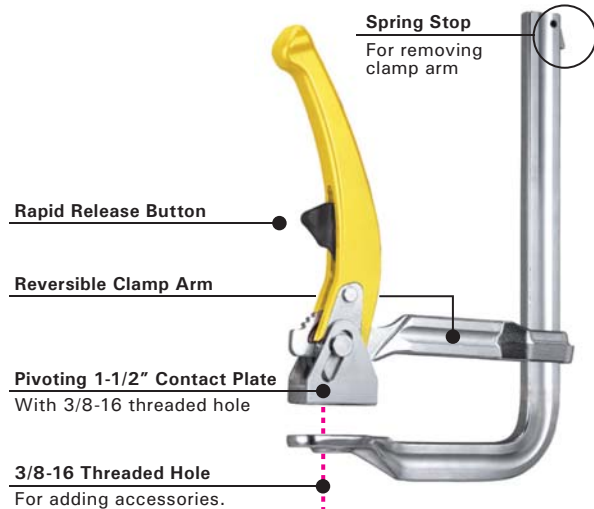

▲ **UF100JR / UF100JRM**  
Sturdy J-shaped 3 inch return for step-over applications.

- Clamping Pressure: 1,000 - 1,200 lbs. (460 - 550 kg)
- Throat Depth: 4-3/4" (120 mm)
- Tapped Hole: 3/8-16 (M10)
- Pivoting Contact Plate with 3/8-16 threaded hole

Part No.	Capacity	Clamping Pressure	Rail Size	Weight
UF65R UF65RM	7" 178 mm	1,000 lbs 450 kg	7/8" x 7/16" 22 mm x 11	2.6 lbs 1.2 kg
UF100R UF100RM	10" 254 mm	1,000 lbs 450 kg	7/8" x 7/16" 22 mm x 11	3.0 lbs 1.3 kg
UF100JR UF100JRM	7" 254 mm	1,000 lbs 450 kg	7/8" x 7/16" 22 mm x 11	3.1 lbs 1.4 kg
UG85R UG85RM	8-1/2" 216 mm	1,200 lbs 550 kg	1" X 15/32" 25 mm x 12	3.6 lbs 1.6 kg
UG125R UG125RM	12-1/2" 318 mm	1,200 lbs 550 kg	1" X 15/32" 25 mm x 12	4.0 lbs 1.8 kg
UG205R UG205RM	20-1/2" 521 mm	1,200 lbs 550 kg	1" X 15/32" 25 mm x 12	4.8 lbs 2.2 kg

## MagSpring™ Clamps

The spring-loaded, one-handed clamp with quick-set magnetic V-Pad.

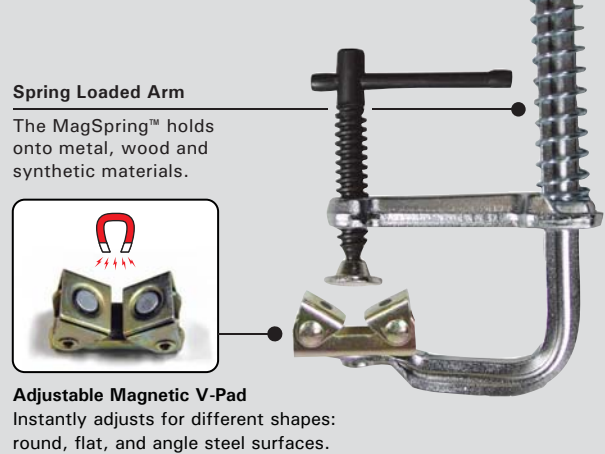

### Quick & Easy to Use!

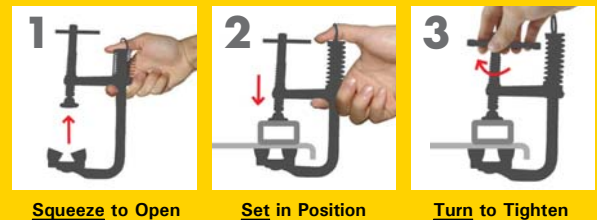

- » The Spring Loaded Arm allows users to free up one hand to position the workpiece.
- » Once positioned, the Adjustable Magnetic Pad holds the clamp to the workpiece for tightening.

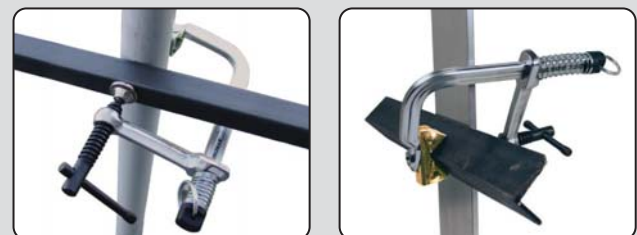

- Clamping Pressure: 300 - 500 lbs. (140 - 230 kg)
- Throat Depth: 2-1/2" - 3-1/4" (64 - 83 mm)
- Tapped Hole: 1/4-20 (M8)

Part No.	Capacity	Throat Depth	Clamping Pressure	Weight
UBV45 UBV45M	3-1/2" 90 mm	2-1/2" 64 mm	300 lbs 140 kg	0.8 lbs 0.4 kg
UBV65 UBV65M	5-1/2" 140 mm	2-1/2" 64 mm	300 lbs 140 kg	0.9 lbs 0.4 kg
UDV45 UDV45M	3-1/2" 90 mm	3-1/4" 83 mm	500 lbs 230 kg	1.0 lbs 0.5 kg
UDV65 UDV65M	5-1/2" 140 mm	3-1/4" 83 mm	500 lbs 230 kg	1.1 lbs 0.5 kg



# EZ Grip Ratchet Clamps & Straight Handles

Multi-Purpose Clamps for woodworking and metalworking.

## EZ Grip Ratchet Clamp

The lightweight, Quick-Set Ratchet Clamp

- » Ideal for firm, no-mar holding of aluminum, wood and non-metallic materials.
- » Hold delicate materials securely in drilling, cutting, assembly, or bending applications. Great for assembly work.
- » The lightweight clamp is easy to handle, easy to set, lock, and release.



### Pull Finger-Loop

For one finger locking.

### Press Release Trigger

**Non Marring Surfaces**  
Protects work surfaces

Included accessories:



**Non Marring Slip On Pads**  
Neoprene cap



**2" (50 mm) Extender Block**  
Part No: VER01  
For Step-Over applications.  
Snaps into jaw hole.

- **Max. Clamping Pressure: 250 lbs. (120 kg)**
- **Throat Depth: 3" (76 mm)**

Part No.	Capacity	Rail Size	Weight
VER45	4.5" 165 mm	3/4 x 1/4" 19mm x 6	0.6 lbs 0.3 kg
VER85	8.5" 215 mm	3/4 x 1/4" 19mm x 6	0.9 lbs 0.5 kg
VER125	12.5" 315 mm	3/4 x 1/4" 19mm x 6	1.3 lbs 0.6 kg
VER165	16.5" 420 mm	3/4 x 1/4" 19mm x 6	1.6 lbs 0.7 kg

## Non-Marring Rubber Pads



Slip-on top and bottom clamp jaws to protect wood, metal, or synthetic work surfaces. Each package contains 2 sets.

## Wood Handle



- **Clamping Pressure: 840 lbs. (380 kg)**
- **Throat Depth: 4" (105 mm)**
- **Standard Pads**

Part No.	Capacity	Rail Size	Tapped Hole	Weight
UE85W UE85WM	8-1/2" 215 mm	3/4" x 3/8" 20 mm x 11	3/8-16 M10	2.2 lbs 1.0 kg
UE125W UE125WM	12-1/2" 315 mm	3/4" x 3/8" 20 mm x 11	3/8-16 M10	2.6 lbs 1.2 kg
UE205W UE205WM	20-1/2" 520 mm	3/4" x 3/8" 20 mm x 11	3/8-16 M10	3.4 lbs 1.6 kg
UE245W UE24WM	24-1/2" 620 mm	3/4" x 3/8" 20 mm x 11	3/8-16 M10	3.8 lbs 1.7 kg

## Economy Light Duty



- **Clamping Pressure: 300 lbs. (140 kg)**
- **Throat Depth: 2-1/2" (65 mm)**
- **Standard Pads**

Part No.	Capacity	Rail Size	Tapped Hole	Weight
UB45A UB45AM	4-1/2" 115 mm	1/2" x 1/4" 13 mm x 6	1/4-20 M6	0.8 lbs 0.4 kg
UB65A UB65AM	6-1/2" 165 mm	1/2" x 1/4" 13 mm x 6	1/4-20 M6	0.9 lbs 0.4 kg
UB85A UB85AM	8-1/2" 215 mm	1/2" x 1/4" 13 mm x 6	1/4-20 M6	1.0 lbs 0.5 kg
UB125A UB125AM	12-1/2" 320 mm	1/2" x 1/4" 13 mm x 6	1/4-20 M6	1.2 lbs 0.6 kg
UB165A UB165AM	16-1/2" 420 mm	1/2" x 1/4" 13 mm x 6	1/4-20 M6	1.3 lbs 0.6 kg
UB205A UB205AM	20-1/2" 520 mm	1/2" x 1/4" 13 mm x 6	1/4-20 M6	1.4 lbs 0.6 kg

Part No.	Description	Weight
XBP2	For UB model clamps	0.1 lbs / 0.1 kg
XDP2	For UD model clamps	0.1 lbs / 0.1 kg
XEP2	For UE model clamps	0.2 lbs / 0.1 kg
XFP2	For UF model clamps	0.2 lbs / 0.1 kg
XGP2	For UG model clamps	0.2 lbs / 0.1 kg

# Adjust-O™ Magnet Squares

The original magnet squares featuring On/Off switches.

Patent No.  
US 7,009,480 B2

## Adjust-O™ Magnet Squares



The fast & easy way to hold metal workpieces at 45° & 90°.

- » Turn the magnet Off when setting up, turn On when you're ready to work. Fast and safe set-up!
- » Ideal for round and square tubing, angle, and flat stock.
- » Easy to clean. Simply turn Off and wipe.

Part No.	Pull Force	Dimension	Weight
MSA45	65 lbs 30 kg	4-3/8" x 3-3/4" x 1" 111 mm x 95 x 25	1.0 lbs 0.5 kg
MSA46-HD	90 lbs 40 kg	4-3/8" x 3-3/4" x 1-1/8" 111 mm x 95 x 29	1.5 lbs 0.7 kg
MSA47	75 lbs 35 kg	6" x 5-1/8" x 1-1/4" 152 mm x 130 x 32	2.2 lbs 1.0 kg
MSA48-HD	160 lbs 75 kg	6" x 5-1/8" x 1-3/8" 152 mm x 130 x 35	3.0 lbs 1.4 kg
● MSA53-HD	140 lbs 65 kg	6" x 5-1/8" x 1-3/8" 152 mm x 130 x 35	3.0 lbs 1.4 kg

\*Magnetic pull force is based on 3/8 steel plates.

### NEW 3rd-Axis Magnetic Posts for Adjust-O™ Magnet Squares

- » Quickly and easily set-up 3-Axis workpieces.
- » Use on either side of the magnet squares.
- » Fits all MSA Adjust-O™ Magnet Squares.



Part No.	Description	Pull Force	Weight
MXE13	3 posts per set	16 lbs 7 kg	0.2 lbs 0.1 kg

\*Magnetic pull force is based on 3/8 steel plates.

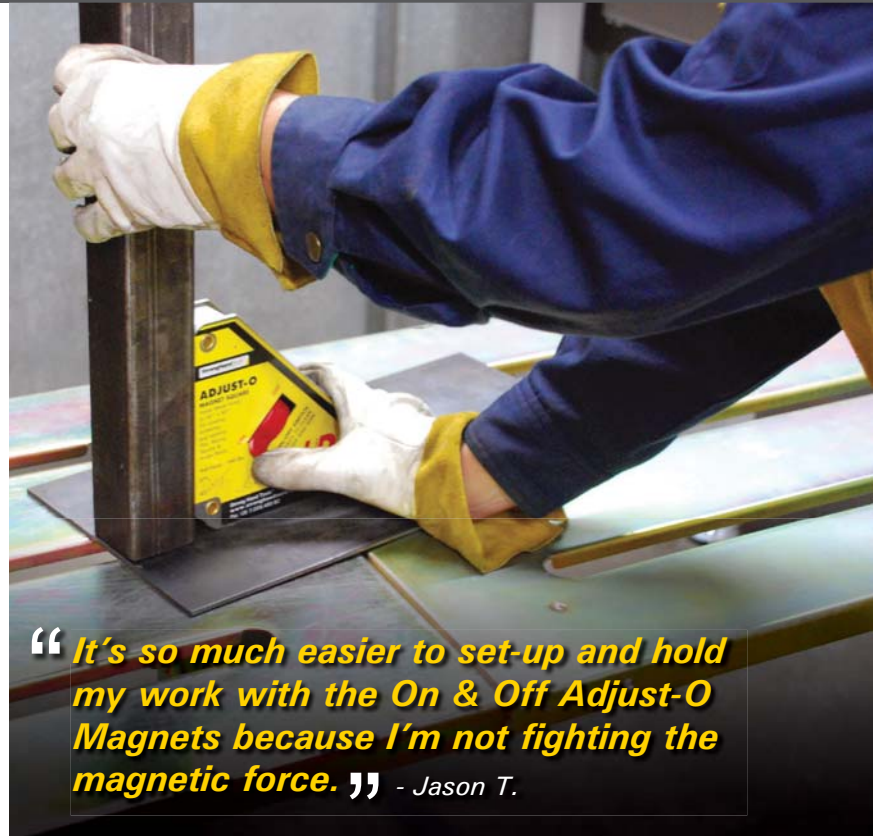

## Adjust-O™ 90° Dual Switch Magnet Squares



For professional jobs that demand strong hold down forces. Hold flat and round metal work pieces.

- » Two On/Off switches for independent operation.
- » Turn the magnets Off when setting up, turn On when you're ready to work. Easy and safe set-up!
- » Precision machined flat and V-surfaces are ideal for round and square tubing, angle, and flat stock.
- » Choose from 120 - 265 lbs (55 - 120 kg) pull force.

Part No.	Pull Force	Dimension	Weight
MS2-80	120 lbs 55 kg	6" x 6" x 1-1/2" 152 mm x 152 x 38	2.7 lbs 1.2 kg
MS2-90	265 lbs 120 kg	7-3/4" x 7-3/4" x 1-7/8" 197 mm x 197 x 48	6.0 lbs 2.7 kg

\*Magnetic pull force is based on 3/8 steel plates.

# Adjust-O™ Angle Magnets & Other Magnets

Multi-angle magnets with the convenience of On/Off switches.

## Adjust-O™ Angle Magnet

- » Adjustable from 30° - 275° with two On/Off switches.
- » Precision machined flat surfaces and nickel/chrome body.
- » V-Groove surfaces securely hold round and square tubing, angle, and flat stock.

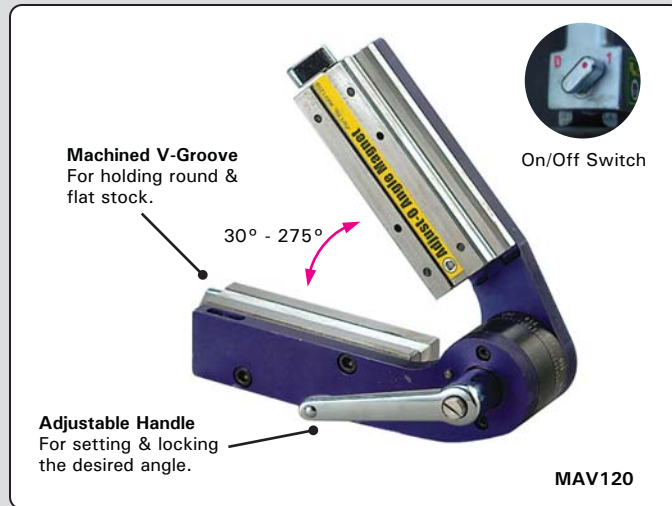

Part No.	Angles	Dimension	Pull Force	Weight
MAV120	30° - 275°	7-3/4" x 7-3/4" x 3-3/4" 197 mm x 197 x 95	110 lbs 50 kg	5.3 lbs 2.4 kg

\* Magnetic pull force is based on 3/8 steel plates.

## Standard Magnet Squares

- » Accurate 30°, 45°, 60°, 90° angles.
- » Center hole for easy handling.

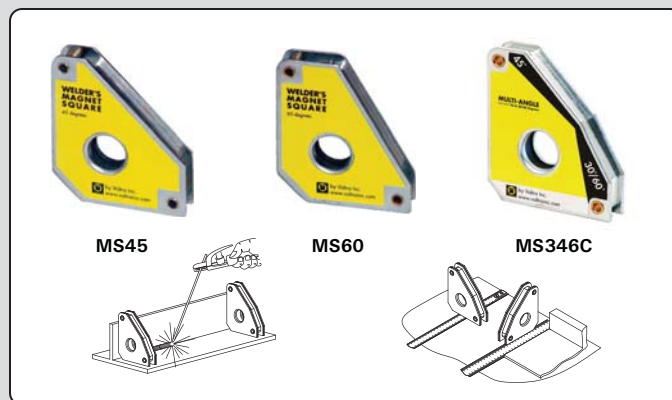

Part No.	Angles	Dimension	Pull Force	Weight
MS45	45° x 90°	4-3/8" x 3-3/4" x 3/4" 111 mm x 95 x 19	65 lbs 30 kg	1.0 lbs 0.5 kg
MS60	60° x 90°	4-3/8" x 3-3/4" x 3/4" 111 mm x 95 x 19	55 lbs 25 kg	1.0 lbs 0.5 kg
MS346C	30°, 60° 45°, 90°	5-1/2" x 4-3/8" x 3/4" 140 mm x 29 x 19	85 lbs 40 kg	1.0 lbs 0.5 kg

\* Magnetic pull force is based on 3/8 steel plates.

## Mini Magnets

Holding at multiple angles while soldering, brazing, and welding at 30°, 45°, 60°, and 90°. The compact size of the Mini Magnets makes it easy to pack, store, and carry for use anywhere!

### Original Mini Magnets

- » Accurate 30°, 45°, 60°, 90° angles.
- » Center hole for easy handling.

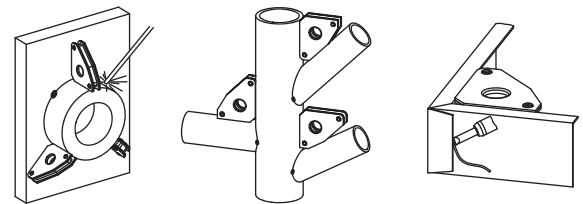

Part No.	Description	Dimension	Pull Force	Weight
MS346AT	Twin Pack	2-5/16" x 2" x 5/8" 59 mm x 51 x 16	25 lbs 10 kg	0.6 lbs 0.3 kg
MS346AK	6-Pack	2-5/16" x 2" x 5/8" 59 mm x 51 x 16	25 lbs 10 kg	1.7 lbs 0.8 kg

\* Magnetic pull force is based on 3/8 steel plates.

## NEW XYZ Mini-Magnets

- » Quickly and easily set-up 2 or 3-Axis workpieces.
- » Re-position, *while* holding. Tap or slide workpieces to fix positioning, without removing the XYZ Mini Magnet!
- » New Magnetic Face Plate features two rare earth disc magnets for 3rd axis holding. Turn the Magnetic Face Plate with your finger to desired position. Quickly snap together 2 or 3 axis set-ups for tack welding.

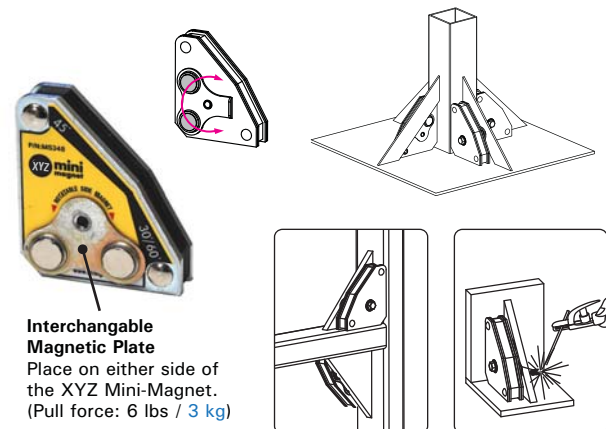

Part No.	Description	Dimension	Pull Force	Weight
MST348	Twin Pack	2-5/16" x 2" x 7/8" 59 mm x 51 x 22	25 lbs 10 kg	0.6 lbs 0.3 kg

\* Magnetic pull force is based on 3/8 steel plates.



# MagTab™, Mag V-Pads & Snake Magnets

Time saving magnetic tools for use in the shop & in the field.

## UNIQUE MagTab™ & New MagTab™ AL

The better, faster way to hold tabs in place for tack welding!

- » Hold tabs, or any small metal pieces, parallel or perpendicular to the substructure.
- » The Adjustable Magnetic V-shape base adjusts for different shapes: round, flat, angle metal surfaces.

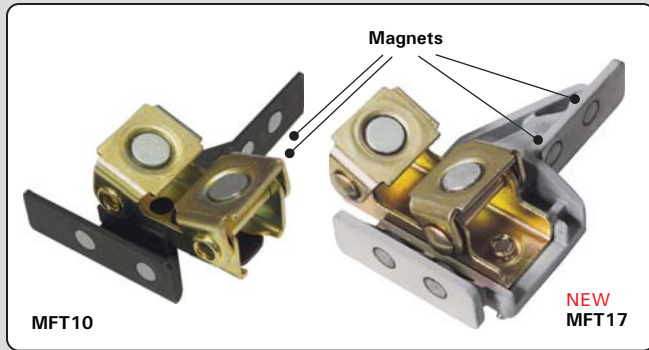

Part No.	Dimension	Pull Force	Weight
MFT10	4" x 3" x 1-1/4" 100 mm x 76 x 32	18 lbs 8 kg	0.5 lbs 0.2 kg
MFT17	4-3/8" x 3" x 1-1/2" 111 mm x 73 x 38	18 lbs 8 kg	0.55 lbs 0.25 kg

\*Magnetic pull force is based on 3/8 steel plates.



Perpendicular tab



Parallel Tab

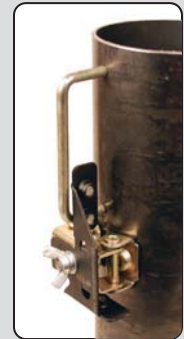

Positioning handle

## NEW MagTab™ AL



- » Made of machined, die cast aluminum for greater accuracy.
- » Two mounting holes provide a wider range of adjustment, and allow for side mounting on pipes and tubes up to 3" in dia.

## NEW Adjustable Magnetic V-Pads

Light duty & tight spot holding! Build, Hold, and Position Steel.

- » Hold and position round, flat, and square parts in light duty substructure applications!
- » Each V-Pad contains 4 rare-earth magnets.

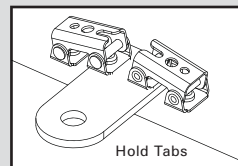

Hold Tabs

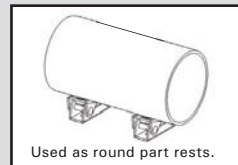

Used as round part rests.

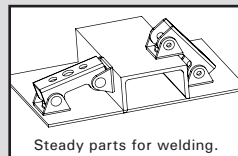

Steady parts for welding.

Part No.	Description	Pull Force	Weight
MVDF44	2 Reg V-Pads (XDV) & 2 Large V-Pads (XVF)	18 lbs 8 kg	0.9 lbs 0.4 kg

\*Magnetic pull force is based on 3/8 steel plates.

## Snake Magnets

The Third Hand - Holds, Bends, Twists

- » Comes complete with 2 magnetic pads and 1 spring clamp.
- » MFC312 has a 12" (305 mm) cable with 2 magnetic V-pads.
- » MFC318 has a 18" (450 mm) cable with 2 flat magnetic pads.

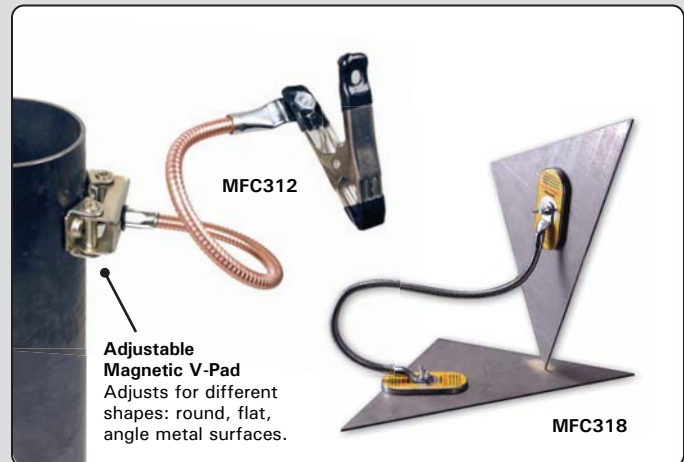

Part No.	Description	Pull Force	Weight
MFC312	12" (305 mm) flex cable, 1 clamp, 2 Adjustable Magnetic V-pads	18 lbs 8 kg	1.0 lbs 0.5 kg
MFC318	18" (450 mm) flex cable, 1 clamp, 2 flat Magnetic Pads	20 lbs 10 kg	1.4 lbs 0.6 kg

\*Magnetic pull force is based on 3/8 steel plates.

# Corner Magnet & Mag-Levels

Innovative magnets and levels with unique and updated features.

## NEW Corner Magnet

- » Create 90° corners by holding from the outside, providing you with an unobstructed area for inside tack welds.
- » One side corner "relief" provides clearance for tall lips.
- » Use the outer edges of the Corner Magnet for setting up materials at 60°.

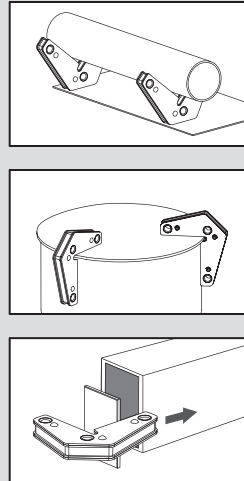

Part No.	Description	Dimension	Pull Force	Weight
MST327	Twin Pack 90° & 60°	3-1/4" x 3-3/4" x 5/8" 83 mm x 95 x 16	30 lbs 14 kg	0.4 lbs 0.2 kg

\* Magnetic pull force is based on 3/8 steel plates.

Patent No. US 7,009,480 B2

## Mag-Level

- » The only magnetic level with the On/Off switch.
- » Holds securely to round and flat surfaces.
- » Three vials for 0°, 45°, 90° reading.

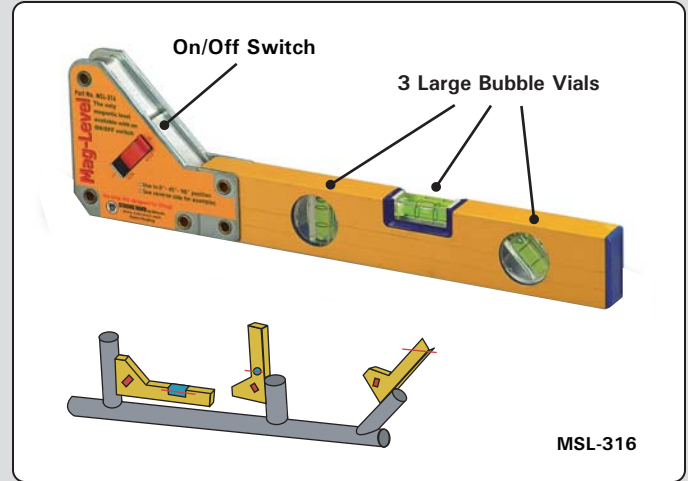

Part No.	Angles	Dimension	Pull Force	Weight
MSL-316	45°, 90°, 180°	4" x 16" x 1" 102 mm x 406 x 25	70 lbs 30 kg	2.0 lbs 0.9 kg

\* Magnetic pull force is based on 3/8 steel plates.

## Torpedo Mag-Levels

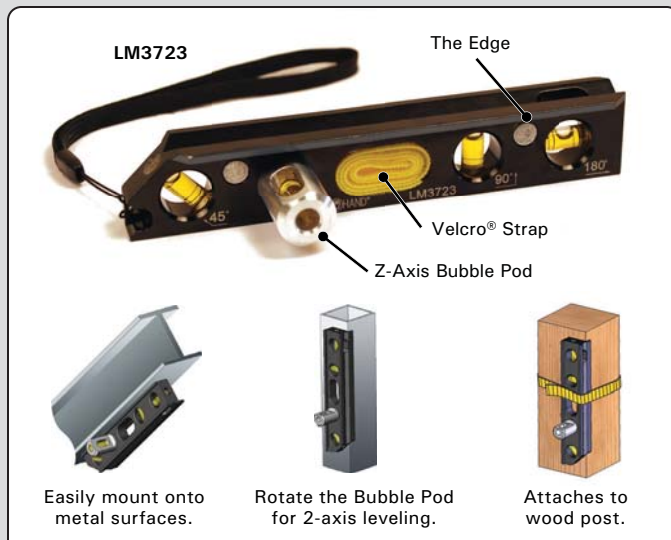

Easily mount onto metal surfaces.

Rotate the Bubble Pod for 2-axis leveling.

Attaches to wood post.

## NEW Mini Torpedo Mag-Level

- » Compact & Light Weight
- » Z-Axis Bubble Pod
- » 1/4" Edge for alignment
- » V-Groove for round parts
- » 4 Magnets



The use-anywhere, view anywhere compact magnetic level.

- » 4 strong magnets allow hands-free use on metal surfaces.
- » V-Groove on one side for pipe and conduit work.
- » Robust, solid anodized aluminum body.



### The 1/4" Edge

Allows the level to be easily aligned with the side of the workpiece.



### Z-Axis Bubble Pod

The add-on pod provides accurate leveling of 2-axes. The pod can be rotated for easy viewing from different angles and heights.



### Elastic Velcro® Strap (LM3723 only)

Allows the level to be easily attached to non-magnetic surfaces. The strap fits snugly into the hole for safe keeping.

Part No.	Angles	Dimension	Weight
LM3723	0°, 45°, 90°	7" x 1-1/4" x 1" 178 mm x 32 x 25	0.4 lbs 0.2 kg
LM2422	0°, 90°	4" x 1-1/4" x 1" 102 mm x 32 x 25	0.3 lbs 0.1 kg

# Improved Locking C-Clamps

Improved features for professionals and do-it-yourselfers.

Made of heat treated steel and nickel/chrome plated for strength and durability. Updated features help you work quickly, safely and efficiently.

**Secure Adjustment Bar**  
Minimizes adjustment bar pop outs.



**Adjustment Screw**  
Large adjustment screw with a hole for easy torque.

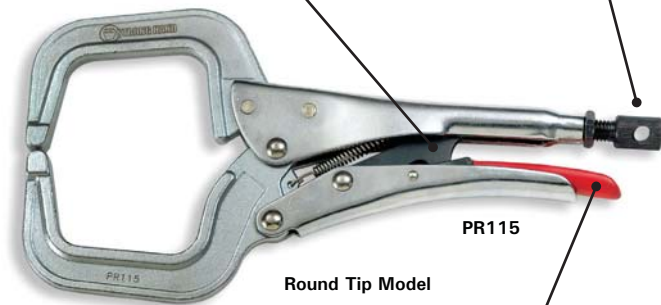
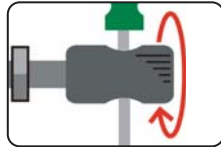

**Optional Crank Handle**  
Can be purchased separately.  
(See accessories page)



**Single Hand Release Handle**  
Vinyl coated release handles made for comfort and ease.



**PR115S**



**PR18S**

	Part No.	OAL	Throat Depth	Opening	Weight
Round Tip	PR6	6-1/2" 165 mm	1-13/16" 46 mm	2-3/16" 56 mm	0.5 lbs 0.2 kg
	PR115	11" 280 mm	3-1/4" 83 mm	4" 102 mm	2.0 lbs 0.9 kg
	PR18	18" 450 mm	10" 254 mm	4-1/2" 114 mm	3.0 lbs 1.4 kg
Swivel Pad	PR6S	6-1/2" 165 mm	1-13/16" 46 mm	2-3/16" 56 mm	0.6 lbs 0.3 kg
	PR115S	11" 280 mm	3-1/4" 83 mm	4" 102 mm	2.2 lbs 1.0 kg
	PR18S	18" 450 mm	10" 254 mm	4-1/2" 114 mm	3.1 lbs 1.4 kg

## Multi-Purpose Pliers

One swivel pad spindle and a fixed head spindle for flexible clamping. Threaded jaw holes allow addition of accessories.



**PG622**



**PG134**

Part No.	OAL	Throat Depth	Opening	Thread	Weight
PG622	6" 150 mm	2" 50 mm	2-1/2" 64 mm	M8	0.5 lbs 0.2 kg
PG634	8-1/2" 215 mm	3" 76 mm	4" 102 mm	M8	1.0 lbs 0.5 kg
PG114 PG114M	11" 280 mm	3-1/2" 89 mm	4" 102 mm	3/8-16 M10	3.0 lbs 1.4 kg
PG134 PG134M	13" 330 mm	5-1/2" 140 mm	4" 102 mm	3/8-16 M10	0.6 lbs 0.3 kg

## Adjustable Reach and Long Reach Multi-Purpose Pliers

Thread : 3/8-16 (M10) | Opening : 4" (102 mm)

**PGA20**  
Adjustable Reach



**PGA20S**  
Adjustable Reach with Fixed Jaw



\*Shown with optional rubber pads.

**PG204**  
Fixed Long Reach



Part No.	OAL	Throat Depth	Weight
PGA20	23" - 29"	14", 16", 18", 20"	4.8 lbs
PGA20M	585 mm - 740	350 mm, 405, 460, 510	2.2 kg
PGA20S	23" - 29"	14", 16", 18", 20"	4.8 lbs
PGA20SM	585 mm - 740	350 mm, 405, 460, 510	2.2 kg
PG204	21"	12-1/2"	3.1 lbs
PG204M	535 mm	254 mm	1.4 kg

**Rubber Pads** for Adjustable Reach / Long Reach Pliers

2 sets per package

• For PG204 & PGA20  
Part No : PP20

• For PGA20S  
Part No : PP20S



# Pipe Pliers

The convenient way to hold round or square tubes for butt-welding.

Hold Round Parts Securely!

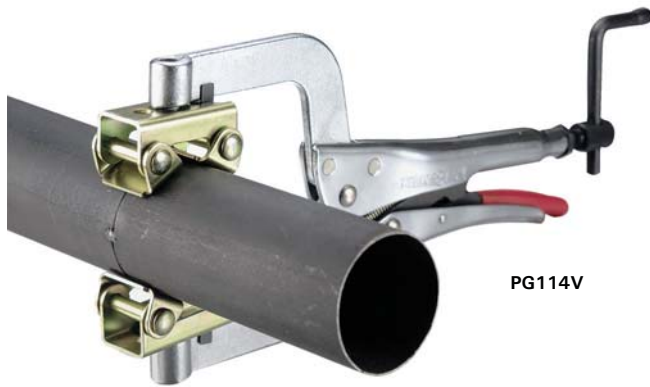

PG114V

The V-Pads on the Pipe Pliers adapt to many different shapes & sizes.



**NEW!**

Pipe Pliers with Adjustable Spindle & Magnetic Bottom V-Pad. (PG635V)

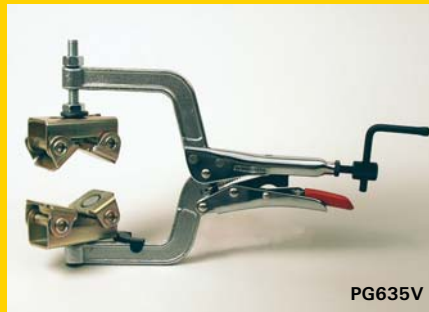

PG635V

Features:

- » Wide opening allows the Pipe Pliers to hold up to 2-1/2" (64 mm) in diameter pipes.
- » Adjustable top spindle for holding pipes of varying sizes.
- » 2 large V-Pads provide a better clamping surface.
- » Magnetic bottom V-Pad securely holds the workpiece in place before clamping.
- » 0° & 45° angle clip allows angled clamping.



Adjustable Spindle

Large Magnetic Bottom V-Pad

Part No.	Features	OAL	Throat Depth	Min / Max Diameter	Thread	Weight
PG622V	» 6" Pliers » Fixed V-Pads (2x XDV)	6" 152 mm	2" 50 mm	1" - 2" 25 mm - 50	M8	0.8 lbs 0.4 kg
PG634V	» 8-1/2" Pliers » Fixed V-Pads (2x XDV)	8-1/2" 215 mm	3" 76 mm	2" - 3" 50 mm - 80	M8	1.1 lbs 0.5 kg
PG635V	» Adjustable Top V-Pad Spindle » Large V-Pads (XFV & XDV)	8-1/2" 215 mm	3" 76 mm	1-1/2" - 2-1/2" 40 mm - 64	M8	1.2 lbs 0.5 kg
PG114V PG114VM	» 11" Pliers » Fixed Large V-Pads (2x XDV)	11" 280 mm	3-1/2" 89 mm	1-1/2" - 2-1/2" 40 mm - 64	3/8-16 M10	2.8 lbs 1.3 kg

Magnetic V-Pads also sold separately  
See Accessories Page 26.

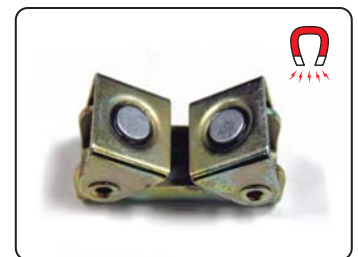

## Bench-Mount Pliers Holder

Convenient "Quick-Grab" Storage

- » Holds in Vertical & Horizontal positions.
- » Wing nuts on both vertical and horizontal position secures and locks pliers in place.

Part No.	Weight
PB11	0.2 lbs 0.1 kg

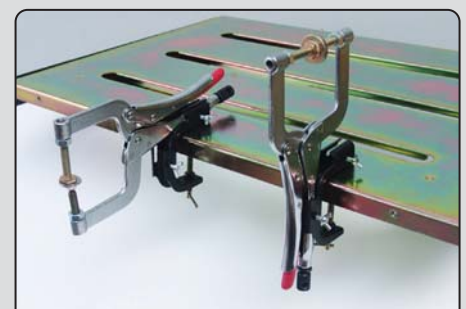

# Locking Chain Pliers & Forged Adjusta-Clamps

The flexibility to clamp around odd shaped items!

## Locking Chain Pliers

Holds 6" (150 mm) pipes with the standard 24" chain.

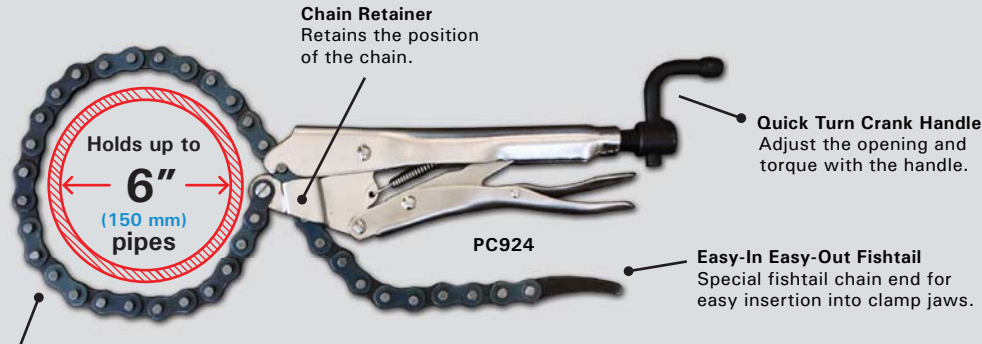

### Replaceable Chain

Unscrew and remove existing chain. Replace with a shorter or longer chain as needed.

- » Clamp around odd or awkwardly shaped items.
- » Hold two workpieces, or a group of materials securely in place while you weld.
- » The **ONLY** Locking Chain Pliers with replaceable chains of various lengths! Chain lengths from 16" to 48".
- » Made of heat treated alloy steel for strength and durability.

Part No.	Description	OAL	Weight
PC924	Standard Chain Pliers with 24" (60 cm) chain	9" 230 mm	1.9 lbs 0.9 kg
PXC16	16" Replaceable Chain	16" 40 mm	0.5 lbs 0.2 kg
PXC36	36" Replaceable Chain	36" 91 mm	1.0 lbs 0.5 kg
PXC48	48" Replaceable Chain	48" 122 mm	1.4 lbs 0.7 kg

• Custom length chains available.

## NEW Forged Adjusta-Clamps

The Rugged Forged Steel Pivot Clamp.

- » Instant height adjustments without blocks or shims. One piece assembly allows for quick setups.
- » Removable brass shims protect machine table and workpiece.
- » Clamp can swing 90° in either direction for loading clearance.

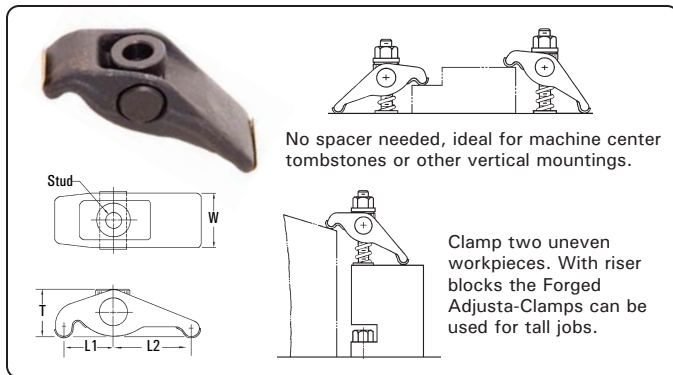

Part No.	Stud Size	Max. Capacity	L1	L2	T	W	Weight
850740	3/8"	1-3/4" 44 mm	1-1/8" 29	1-7/8" 48	1" 25	1-1/4" 32	9 oz 0.3 kg
850750	1/2"	2-1/16" 52 mm	1-7/16" 37	2-5/16" 59	1-7/16" 37	1-5/8" 41	17 oz 0.5 kg
850760	5/8"	3" 76 mm	2" 50	3-1/4" 83	1-7/8" 48	1-7/8" 48	2.4 lbs 1 kg

• Visit our website at [www.valtrainc.com](http://www.valtrainc.com) for more information.

## NEW Handi-Hammer - The handle-less Tapper!

The Unique Dead-Blow Tapper

- » One Steel End for hard surfaces.
- » One Soft Face for non-marring applications.
- » Eliminates bounce back and increases impact.
- » Fits easily in Tool Kits, Tool Boxes & Work Bench Drawers.
- » Ideal for confined areas!



Part No.	Dimension	Weight
CH-10	1-5/8"Ø x 5" 40 mm Ø x 127	0.6 lbs 10 oz
CH-14	1-3/4"Ø x 5-1/4" 45 mm Ø x 133	0.9 lbs 14 oz

# Table Mount C-Clamps & Expand-O Pliers

The only expanding and spreading pliers in the market.

## Table Mount Locking C-Clamps



PTT934

- » Mounts directly to any work bench, drill press, etc.
- » Mounting base hole accepts standard 5/16"-18 bolts and uses push-down action to hold your workpiece securely.
- » Use the L-Handle for rapid tightening
- » Rapid lock and release. Ideal for repetitious clamping.

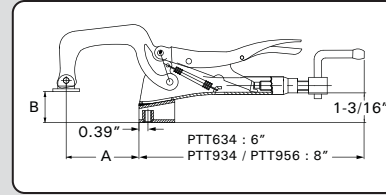

Part No.	Throat Depth (A)	Max. Capacity (B)	Mount Thread	Weight
PTT634 PT09	3" 76 mm	4" 102 mm	5/16-18 M8	0.9 lbs 0.4 kg
PTT934 PT11	3-3/8" 86 mm	4" 102 mm	5/16-18 M8	1.6 lbs 0.7 kg
PTT956 PT14	6-1/8" 155 mm	4-3/4" 120 mm	5/16-18 M8	2.0 lbs 0.9 kg

## Expand-O Pliers

### Unique, Reverse-Action Clamping Pliers!

Jaws move in opposite directions to push against two surfaces.

Patent No. US 6,993,999 B2

Ideal for Metal or Wood working.

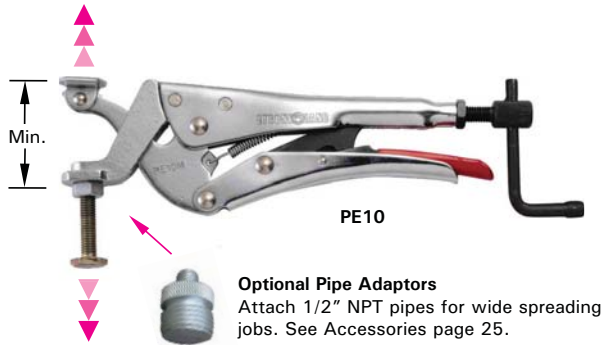

**Optional Pipe Adaptors**  
Attach 1/2" NPT pipes for wide spreading jobs. See Accessories page 25.

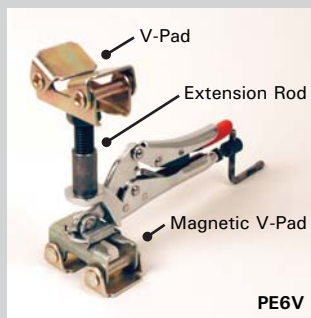
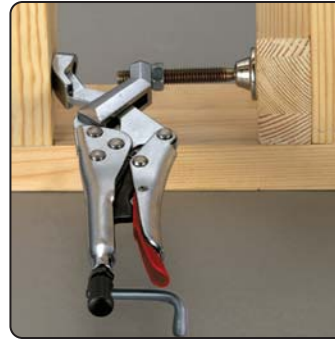

PE6V

### NEW! Expand-O Pliers with V-Pads and Extension Rod! (PEV6 & PEV10)

#### Features:

- » One Magnetic V-Pad, One Standard V-Pad.
- » Use the Extension Rod to increase reach by 1" - 2".
- » Use the bottom Adjustable Magnetic V-Pad to set the pliers in place.
- » When expanding, the two V-pads instantly adjust to round or flat surfaces.

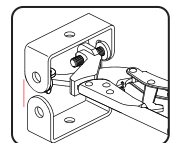

Expand brackets

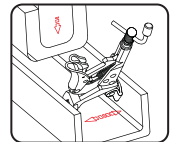

Insert panel into U-channel

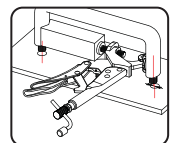

Align to fit holes

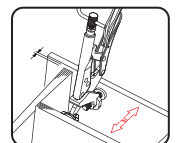

Separate cabinets

Part No.	OAL	Clamping Pressure	Thread	Min.	Stroke	Weight
PE6 PE6M	6-1/2" 165 mm	500 lbs 230 kg	5/16-18 M8	1" 25 mm	3/4" 19 mm	0.5 lbs 0.2 kg
PE10 PE10M	10" 255 mm	900 lbs 410 kg	3/8-16 M10	1-3/8" 35 mm	1-3/8" 35 mm	1.8 lbs 0.8 kg
PEV6	6-1/2" 165 mm	500 lbs 230 kg	5/16-18 M8	1" 25 mm	3/4" 19 mm	0.8 lbs 0.4 kg
PEV10	10" 255 mm	900 lbs 410 kg	3/8-16 M10	1-3/8" 35 mm	1-3/8" 35 mm	2.4 lbs 1.1 kg



# Welders Angle Clamps

## 2 and 3 Axis Fixture Visers

### 3-Axis Welders Angle Clamps

Patent No. US 6,860,475 B2

Holds a 3-axis workpiece in position before welding.

- » Features the Quick Acting Screws and "Swing Away" Arm.

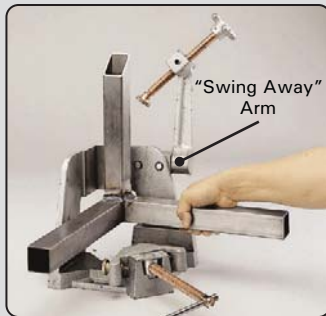
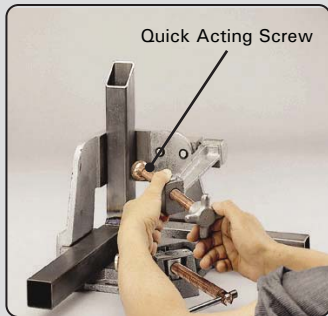

- » With the push of the buttons, the threaded screws easily slide in and out.
- » When the job is finished, simply "swing away" the 3rd Axis arm for quick and easy part removal.
- » Hold parts in position during cool down to minimize distortion due to contraction.
- » Available in 3.75" and 4.75" capacities. Model WAC45-SW comes with a curved arm for greater workpiece clearance.

### 2-Axis Welders Angle Clamps

Made with machined cast iron. Featuring these improvements:

- » Machined outside faces - usable for upright joint
- » Stand-off increases access
- » Quick acting screw on deluxe models.

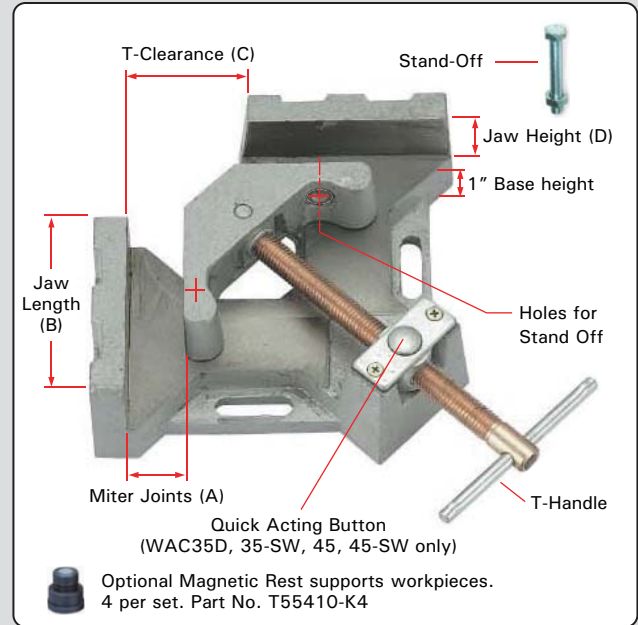

	Part No.	Features	Miter Joints (A)	Jaw Length (B)	T-Clearance	Jaw Height (D)	Weight
2-Axis	WAC22	Standard screw, Machined on two outside surfaces	2.21" 56 mm	3.54" 90 mm	1.85" 47 mm	1.28" 33 mm	8.8 lbs 4.0 kg
	WAC34	Standard screw	3.75" 95 mm	4.80" 122 mm	2.45" 62 mm	1.38" 35 mm	11 lbs 5.0 kg
	WAC35D	Quick Acting Screw, Two stand-offs, Machined on two outside faces	3.75" 95 mm	4.80" 122 mm	2.45" 62 mm	1.38" 35 mm	11 lbs 5.0 kg
	WAC45	Quick Acting Screw, Two stand-offs, Machined on two outside faces	4.75" 121 mm	5.32" 135 mm	3.92" 100 mm	2.25" 57 mm	23 lbs 11.0 kg
3-Axis	WAC35-SW	3-Axis Fixture, Quick Acting Screw, Two stand-offs "Swing Away" Arm	3.75" 95 mm	4.80" 122 mm	2.45" 62 mm	1.38" 35 mm	24 lbs 11 kg
	WAC45-SW	3-Axis Fixture, Quick Acting Screw, Two stand-offs "Swing Away" Arm, Two magnetic rests	4.75" 121 mm	5.32" 135 mm	3.92" 100 mm	2.25" 57 mm	43 lbs 20 kg

\* Optional Magnetic Rest supports workpieces. 4 per set. Part No. T55410-K4

# Portable MagVise™ & 90° Tru Angl

Time saving aluminum vises for use in the shop and in the field.

## NEW Portable MagVise™

Use the lightweight, compact Portable MagVise for quick 90° clamping in the shop, or in the field!

Magnets in the walls instantly hold pipes, tubes, angle iron, or metal plates in position for fast, accurate clamping at 90°.

### Model WK50

Features the Quick-Acting Adjustable Spindle. Press and hold the Quick Acting Button and the spindle assembly slides in and out for a super fast set-up! Release the button and the threads re-engage for tightening.

### Model WP60

Features a Plier/Vise combination for clamping flat workpieces, such as metal plates and angle iron. The Pliers can be positioned on either side of the MagVise for clamping in the front, or back of your workpiece, leaving an unobstructed area for welding.

### Optional Magnetic Rests

Part No. T55410-K4

4 pcs. per set

These handy Magnetic Rests are ideal for light duty holding, positioning, or steadying long metal pieces and parts.



**WK50**  
MagVise™ with Quick Acting Adjustable Spindle

**WP60**  
MagVise™ with Pliers

**WP601**  
MagVise Only



The rotateable spindle allows for holding workpieces with different thicknesses.

The pliers can mount on either side of the MagVise.



Use the provided leveling screw and optional Magnetic Rests to level long workpieces.

When the job is finished, easily slide the pliers out of the WP60 MagVise.

Part No.	Description	Base Height	Jaw Length	Jaw Height	Max Capacity	Weight
WK50	MagVise™ with Adjustable Spindle	1" 25 mm	3.35" 85 mm	1.2" 30 mm	2" 50 mm	1.7 lbs 0.8 kg
WP60	MagVise™ with Pliers	1" 25 mm	3.35" 85 mm	1.2" 30 mm	2" 50 mm	1.9 lbs 0.9 kg
WP601	MagVise™ Only	1" 25 mm	3.35" 85 mm	1.2" 30 mm	-	0.9 lbs 0.4 kg

## Aluminum 90° Tru-Angl

- » Accurate Right Angle Fixture is CNC machined for accuracy.
- » Weld spatter proof & made of high strength aluminum alloy.
- » Holds round, square, flat and angle shapes.
- » Works on both the outside and inside surfaces.

Part No.	Jaw Length (A)	Jaw Height	T-Clearance (B)	Weight
LF-2	7" 178 mm	1-1/2" 38 mm	2-1/2" 64 mm	3.0 lbs 1.4 kg

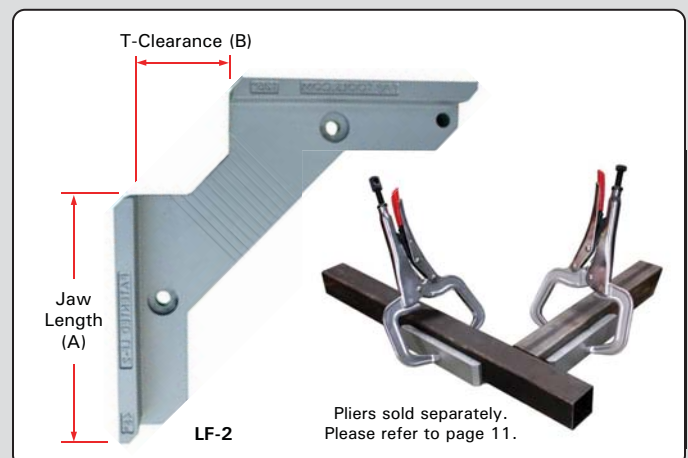

# JointMaster™ Angle Clamping Tools

Fast, precise and affordable clamping tools for corners and T-joints.

## PL Series

The single-hand corner clamping tool.

- » Ideal for quick hold and release on metal, wood & synthetic materials.
- » A "helping hand" to hold stock firmly at right angles while creating or repairing permanent joints.
- » PL Series comes with 1 pair of pliers.

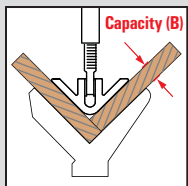

Capacity (B):  
PL622 : 0 - 3/4"  
PL634 : 0 - 1-1/4"

## PT Series

The 90° Fixed JointMaster™

- » Retractable plate for edge alignment
- » V-Grooves for holding round pieces.
- » Ideal for holding two pieces of different thicknesses that require individual adjustments.
- » PT Series comes with 2 pairs of pliers.

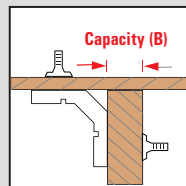
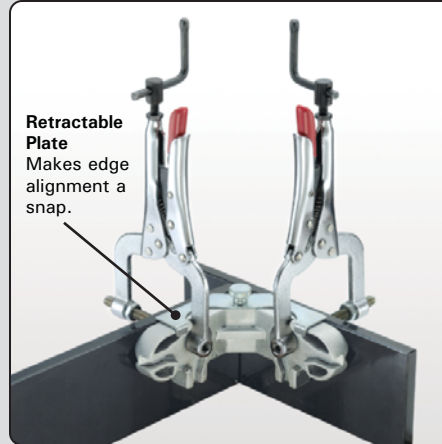

Capacity (B):  
PL622 : 0 - 1-1/4"  
PT634 : 0 - 3"

## PA Series

The Adjustable JointMaster™

- » Adjustable from 30° - 275°.
- » Adjust to the desired angle & "lock" into position with the handle.
- » Join round & flat workpieces, or materials with different thicknesses.
- » PA Series comes with 2 pairs of pliers.

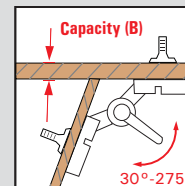

Capacity (B):  
PA622 : 0 - 1-1/4"  
PA634 : 0 - 3"

## 90° Clamp

- » A quick way to hold workpieces at 90°.
- » Capable of holding a 3-axis workpiece by adding a Pipe Pliers (see pg.12).
- » Wide opening offers unobstructed welding access.



PL / PT / PA Series

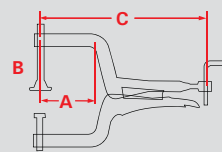

UDL365

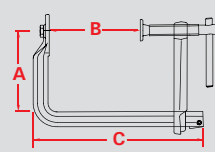

Part No.	Throat Depth (A)	Max. Capacity (B)	OAL (C)	Weight
PL622	2" 50 mm	3/4" 19 mm	7-1/2" 190 mm	1.0 lbs 0.5 kg
PL634	3" 76 mm	1-1/4" 32 mm	8-1/2" 216 mm	1.1 lbs 0.5 kg
PT622	2" 50 mm	1-1/4" 32 mm	7-1/2" 190 mm	1.6 lbs 0.7 kg
PT634	3" 76 mm	3" 76 mm	8-1/2" 216 mm	2.5 lbs 1.1 kg
PA622	2" 50 mm	1-1/4" 32 mm	7-1/2" 190 mm	2.0 lbs 0.9 kg
PA634	3" 76 mm	3" 76 mm	8-1/2" 216 mm	2.4 lbs 1.1 kg
UDL365	3" 76 mm	2" 50 mm	9-1/2" 241 mm	1.7 lbs 0.8 kg



# PowerBase & Ground Hog Grounding Tools

Power through your grounding applications!

## NEW PowerBase™ Grounding Magnet



Power through your grounding applications!

- » The PowerBase™ Grounding Magnet sets up quickly and easily. Start grounding instantly!
- » Powerful rare earth magnet delivers heavy duty holding power.
- » The “V” machined surface grips round parts.
- » The copper connector stud is located on top and allows for a full 360° cable rotation.
- » Rugged, compact steel housing for a fast and safe ground, even in tight spots!



Turn OFF the PowerBase™ Grounding Magnet and metal chips fall away.

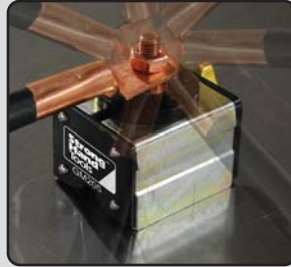

The copper connector on top allows for 360° cable rotation.



Holds securely onto round or flat surfaces.



The ON/OFF Lever is easy to turn, even while wearing gloves.

Part No.	Amperage	Dimension	Magnetic Force	Weight
GM203	300A @ 60% Duty Cycle	2" x 2" x 1.4" 50 mm x 50 x 64	75 lbs 34 kg	0.9 lbs 0.4 kg
GM205	500A @ 60% Duty Cycle	2" x 2.75" x 1.4" 50 mm x 70 x 64	110 lbs 50 kg	2.4 lbs 1.1 kg

## Ground Hog™ Clamps



High clamping pressure improves arc stability and reduces power consumption.

- » Prevents current restriction and allows a complete transfer of the electrical current.
- » Controls the electrical current by isolating the contact surface and the cable connection.
- » Get a smooth, continuous arc with no fade, and no heat transfer while improving cable life, and reducing power consumption.

The Ground Hog

- » The groove design on the copperhead seals out weld spatter and reduces particle buildup.
- » Side screw provides a secure cable connection.
- » Ground Hog body rotates for cable positioning.

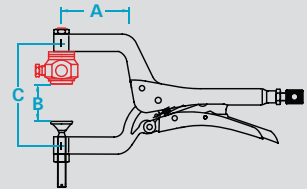

Part No.	Amperage / Cable Size	Throat Depth (A)	Max. Opening (B)	Tapped Hole (C)	Clamping Pressure	OAL	Weight
GP630 GP1530	300A 2/0 - 0.427"	3" 76 mm	1-1/4" 32 mm	5/16-18 M8	240 lbs 110 kg	6" 150 mm	0.9 lbs 0.4 kg
GP950 GP2850	450A 2/0 - 0.427"	3-1/2" 89 mm	2-1/2" 64 mm	3/8-16 M10	400 lbs 180kg	11" 280 mm	2.4 lbs 1.1 kg
GP951 GP2851	530A 3/0 - 0.475"	3-1/2" 89 mm	2-1/2" 64 mm	3/8-16 M10	400 lbs 180kg	11" 280 mm	2.4 lbs 1.1 kg

# Platen Clamps & Hold Down Clamps

Hold down action clamps with unique features and accessories.

## Modular Platen Clamps

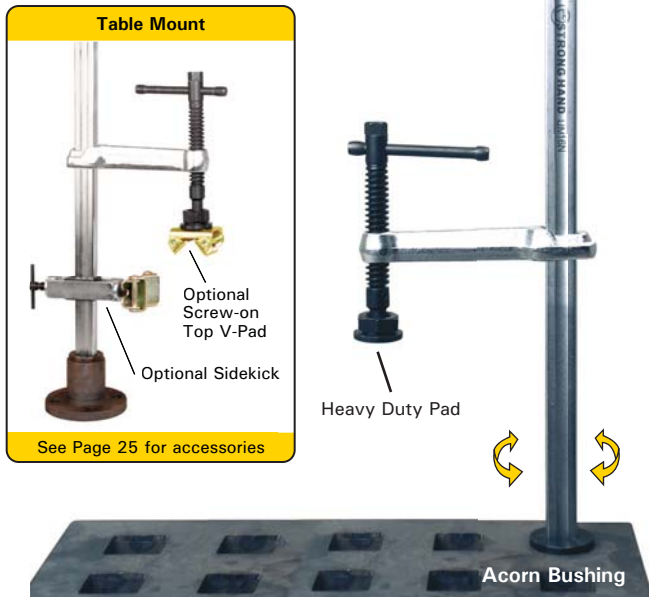

For fast, secure clamping, simply insert the clamp into the 1-3/4" square hole in your acorn platen. Slide the clamp arm down to the work piece and turn the T-Handle to tighten.

- » Choose from Acorn Bushing or Table Mount Models.
- » Clamp comes with standard or heavy duty Swivel Pads.
- » Unique optional Side-Kick Attachment provides push-action horizontal clamping force. (See accessories page)
- » Optional V-Pads can be mounted on the Sliding Arm or Side-Kick Attachment. (See accessories page)

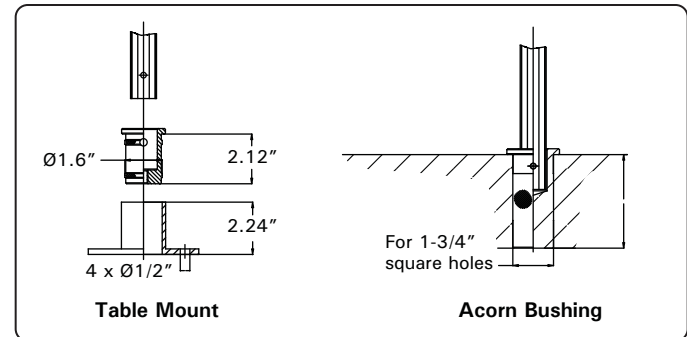

### Table Mount

Part No.	Rail Size	Pad	Opening	Throat
UF8NC	"F"	Standard	8" 203 mm	4-3/4" 120 mm
UF10NC	"F"	Standard	10" 254 mm	4-3/4" 120 mm
UF12NC	"F"	Standard	12" 305 mm	4-3/4" 120 mm
UM12NC	"M"	Heavy Duty	12" 305 mm	5-1/2" 140 mm
UM16NC	"M"	Heavy Duty	16" 406 mm	5-1/2" 140 mm
UM20NC	"M"	Heavy Duty	20" 508 mm	5-1/2" 140 mm

### Acorn Bushing

Part No.	Rail Size	Pad	Opening	Throat
UF8NA	"F"	Standard	8" 203 mm	4-3/4" 120 mm
UF10NA	"F"	Standard	10" 254 mm	4-3/4" 120 mm
UF12NA	"F"	Standard	12" 305 mm	4-3/4" 120 mm
UM12NA	"M"	Heavy Duty	12" 305 mm	5-1/2" 140 mm
UM16NA	"M"	Heavy Duty	16" 406 mm	5-1/2" 140 mm
UM20NA	"M"	Heavy Duty	20" 508 mm	5-1/2" 140 mm

## NEW Hold Down Clamps



- » Bolt the clamp down to your worktable using the 3/8" hole in the base.
- » The 1/2" copper plated Acme spindle resists weld spatter, and the swivel tip makes quick contact with your workpiece.
- » Hold pipes by adding our Clip-On V-Pad, Part #XDA2. (See accessory page 26).

Part No.	Capacity	Weight
VHD30	2-3/4" 70 mm	2.0 lbs 0.9 lb

Copper Plated  
Acme Screw /  
Ductile Iron Body

# Shark Clamps, Half Clamps & Side Clamps

Precise scissor action clamps with the Quick Acting Buttons.

## Shark Clamps

Patent No. US 6,983,012 B2



Shown with optional rubber pads. (P/N: SCP)

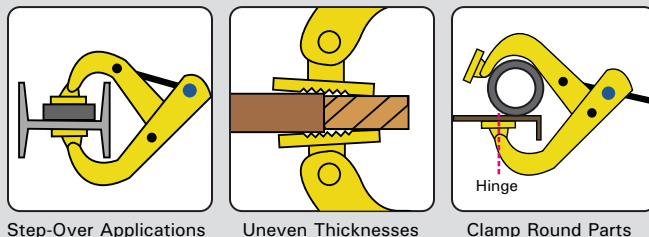

**Fast Set-ups**, just hold the button down and pull-push the handle to desired clamping position, release the button and turn the handle to tighten.

Part No.	Description	Pull Force	Opening	Weight
SC50	T-Handle	1,000 lbs 455 kg	5" 127 mm	2.2 lbs 1.0 kg
SC50A	Straight Handle	300 lbs 135 kg	5" 127 mm	2.0 lbs 0.9 kg
SC65	T-Handle	1,000 lbs 455 kg	6-1/2" 165 mm	2.5 lbs 1.1 kg
SC65A	Straight Handle	300 lbs 135 kg	6-1/2" 165 mm	2.2 lbs 1.0 kg

## Half Clamps

Patent No. US 6,983,525 B2

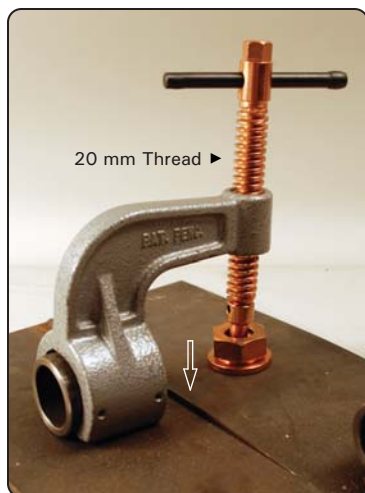

### The Efficient, Safe Way to Align Materials.

- » The DOG & WEDGE and CUT-OFF C-CLAMP methods of material alignment are messy, time consuming, and unsafe!
- » Align materials in the fabrication of water tanks, bulkheads, deck sections, flat plates, etc.
- » For big jobs, tack weld additional 1-1/2" cut pipes along the joint.

### How to Use

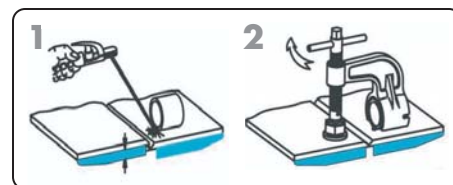

Tack weld the front side of 1-1/2" pipe coupon to the lower of the two surfaces. Slide Half Clamp onto the cut pipe, turn the handle until the misaligned materials align.

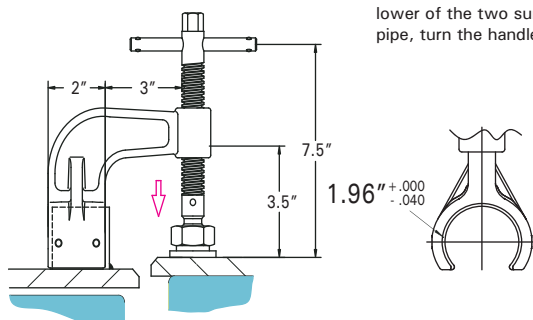

Copper Plated Acme Screw / Ductile Iron Body

Part No.	Weight
VHC15	3.7 lbs 1.7 kg

## Side Clamps

**Build push-action clamp to custom heights.** Insert pipe (1-1/2" dia.) of desired length. Base can be bolt-mounted to the table.

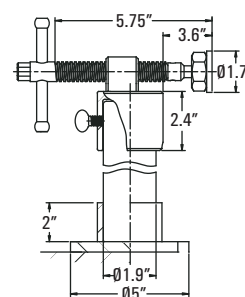

Copper Plated Acme Screw / Ductile Iron Body

Part No.	Weight
VSC15	5.6 lbs 2.6 kg



# NOMAD™ Economy Welding Table

Very Affordable. Fully Adjustable. Easily Movable.

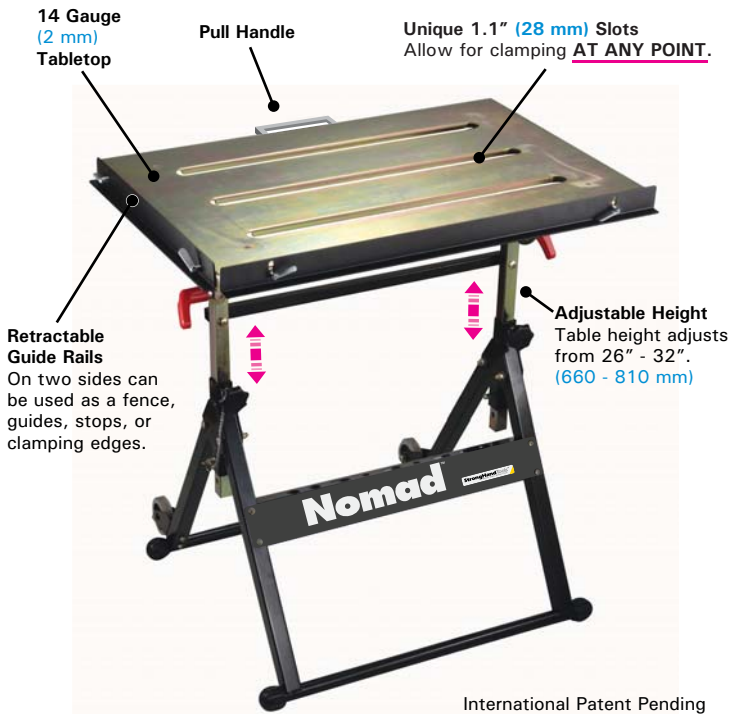

- » Three 1.1" (28mm) slots in the tabletop allow for insertion of clamps to reach any point on the table.
- » Tabletop tilts to three positions: Horizontal, 30°, and folded for mobility.
- » Two retractable, perpendicular steel guide rails can be used as guides, stops, or clamping edges.
- » Tabletop height can be adjusted from 26" to 32".
- » Table moves about the work area on 2 sturdy casters.

**Tabletop adjusts to three positions:**  
Horizontal, 30°, and Folded for Compact Storage and Mobility.



Part No.	Tabletop Size	Table Height Range	Slots in Tabletop	Table Positions	Load Capacity	Weight
TS3020	30" W x 20" L 760 mm x 510	26" - 32" 660 mm - 810	1.1" 28 mm	0°, 30°, Folded	350 lbs 160 kg	44 lbs 20 kg

## Nomad™ Economy Tool Kit

This 6 piece tool kit contains useful tools to use in conjunction with the table.

Part No. TSK104 (TSK104M)

- » 2 MagSpring Clamps (UBV45)
- » 1 Multi-Angle Magnet (MS346C)
- » 1 Mini-Magnet (MS346A)
- » 2 Adjustable Magnet V-Pads (XDV4)

2 MagSpring™ Clamps (UBV45 - 3-1/2" Cap.)

1 Multi-Angle Magnet (MS346C)

1 Mini Magnet (MS346A)

2 Adjustable Magnetic V-Pads (XDV4 - 4 magnets)



## NEW Nomad™ Connector Plate

Need more tabletop workspace? Use the Nomad™ Connector Plate to join two Nomad Tables together to create a 7.5' (2.3 m) long workstation!

Clamp and work on larger projects, or multiple projects with the fully adjustable work surface! There are thru holes on all four sides of the Connector Plate for multiple mounting options.

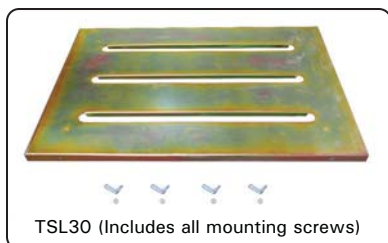

Part No.	Weight
TSL30	16.4 lbs 7.4 kg

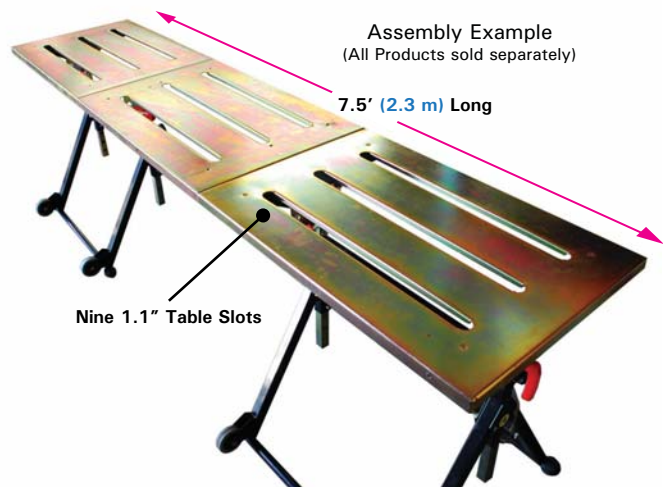

# New! Twin Slot Base Toggle Clamps

Stackable Magnetic Riser Blocks & Shims available

The ease and speed of a Toggle Clamp combined with the new, unique Quick-Mount Slotted Base, and Knobbed Spindle. These Toggle Clamps are ideal for holding a workpiece in a positive location for quick and easy clamping in repetitious work.

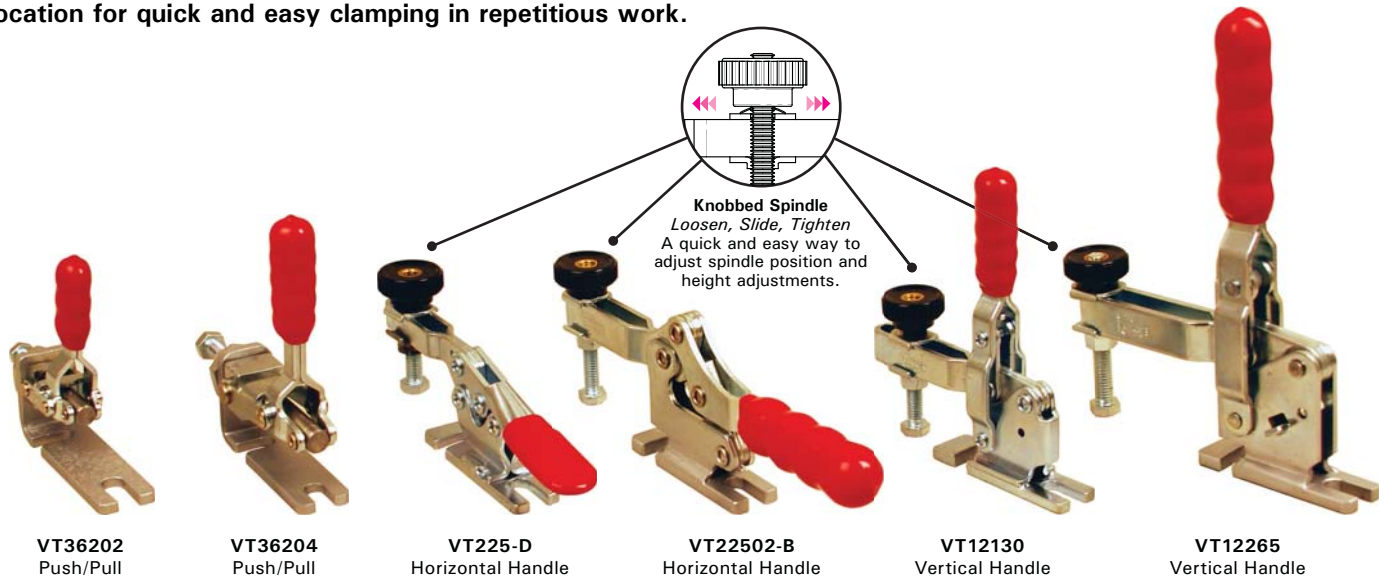

## Quick-Mounting!

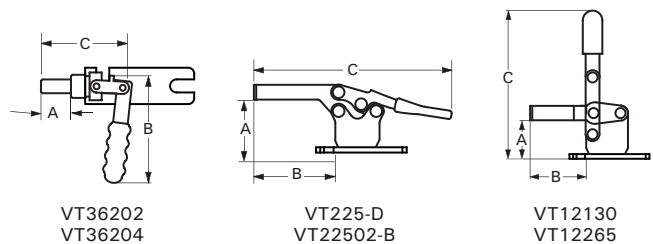
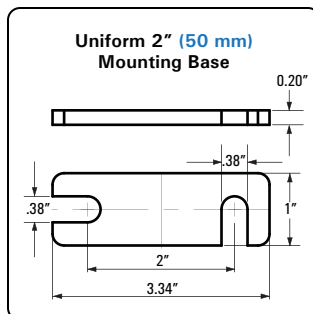
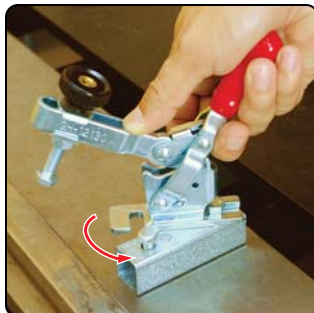

The unique twin-slotted base allows the clamp to slide onto two 5/16-18 Hex Head Screws for quick mounting, and removal. Now you can mount and use a Toggle Clamp anywhere, without creating a permanent, dedicated set-up. Front and rear slots are set in a perpendicular configuration for secure slide-in mounting.

Part No.	Description	Capacity	A	B	C	Plunger Stroke	Weight
VT36202	Push/Pull	200 lbs	0.81	3.0	2.5	0.75	0.5 lb
VT36204	Push/Pull	300 lbs	1.56	3.9	4.5	1.50	0.8 lb
VT225-D	Horizontal	500 lbs	1.37	2.75	6.61	-	0.6 lb
VT22502-B	Horizontal	550 lbs	1.34	3.11	8.62	-	1.0 lb
VT12130	Vertical	500 lbs	1.25	2.81	5.50	-	0.8 lb
VT12265	Vertical	750 lbs	1.75	3.58	7.50	-	1.4 lbs

UNIT: inches

## Stackable Magnetic Riser Blocks & Shims Kit

For taller workpieces, use the Magnetic Riser Blocks and Shims Kit to mount the Slotted Base Toggle Clamps at the desired height. The Magnetic Riser Blocks feature twin holes for use in either vertical or horizontal position. Use the Shims for *incremental* height adjustments.

The 6 pc. kit comes complete with:



### 2 Magnetic Riser Blocks

- 1 25 x 25 x 85 mm (1" x 1" x 3.34")
- 1 25 x 50 x 85 mm (1" x 2" x 3.34")

### 4 Shims

- 2 25 x 3 x 85 mm (1" x 0.12" x 3.34")
- 2 25 x 5 x 85 mm (1" x 0.20" x 3.34")



Riser Blocks and Shims use in conjunction with the VT36202 Toggle Clamp.

## Optional Threaded Adaptors



Part No. TXT5203  
Weight: 0.25 lb.

Convert work surface holes to 5-16/18. Magnetized Threaded Adaptor Plate mounts underneath your work surface, and provides two 5/16-18 threaded holes.

Part No.	Description	Weight
VTX6400	6 pc. Magnetic Riser Blocks & Shims Kit	0.77 lb



# Good Hand™ Toggle Clamps

Ideal time-saving jig and fixture clamps.

## Vertical Handle Hold Down Action



GH-12050

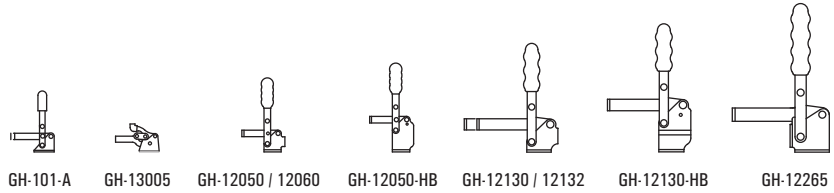
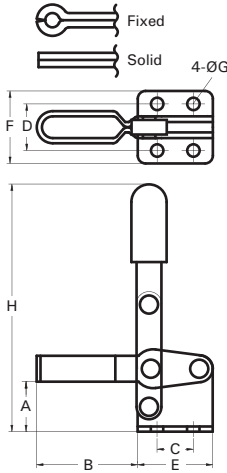

Part No.	Bar	Capacity	A	B	C	D	E	F	ØG	H	Weight
GH-101-A	U	110 lbs	0.75	1.02	0.63	0.94	1.00	1.31	0.17	3.03	0.13 lb
GH-13005	U	150 lbs	0.50	1.21	0.53	0.63	1.03	1.00	0.17	1.40	0.13 lb
GH-12050	Fixed	200 lbs	0.89	1.30	0.50	1.06	1.00	1.56	0.20	3.74	0.38 lb
GH-12050-HB	Fixed	200 lbs	0.66	1.30	0.50	1.06	1.00	1.56	0.20	4.8	0.38 lb
GH-12060	Solid	200 lbs	0.89	1.30	0.50	1.06	1.00	1.56	0.20	3.74	0.38 lb
GH-12130	U	500 lbs	1.25	2.81	0.75	1.25	1.37	1.81	0.28	5.50	0.78 lb
GH-12130-HB	U	500 lbs	2.25	2.81	0.75	1.25	1.75	1.81	0.28	6.50	0.78 lb
GH-12132	U	500 lbs	1.25	3.75	0.75	1.25	1.37	1.81	0.28	5.50	0.81 lb
GH-12265	U	750 lbs	1.75	3.58	1.25	1.78	1.94	2.53	0.34	7.50	1.40 lb

UNIT: inches

## Horizontal Handle Hold Down Action



GH-201-B

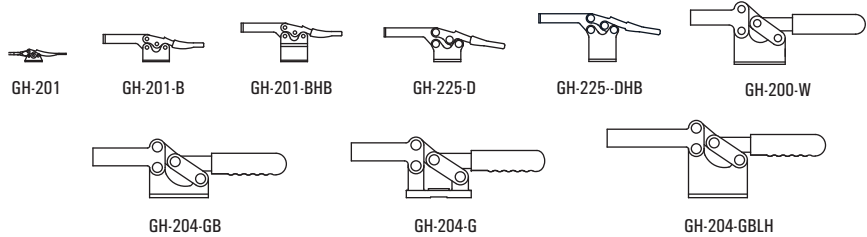
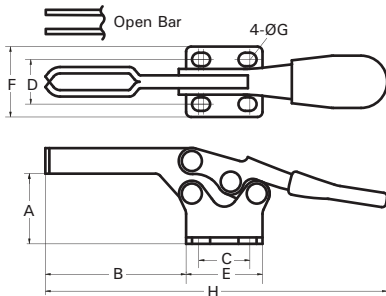

Part No.	Bar	Capacity	A	B	C	D	E	F	ØG	H	Weight
GH-201	U	60 lbs	0.37	0.87	0.63	0.63	0.94	0.94	0.17	3.11	0.09 lb
GH-201-B	U	200 lbs	1.00	2.17	1.06	0.87	1.45	1.42	0.20	5.43	0.29 lb
GH-201-BHB	U	200 lbs	1.66	2.17	1.06	0.87	1.45	1.42	0.20	5.43	0.32 lb
GH-225-D	U	500 lbs	1.37	2.75	1.00	0.87	1.50	1.42	0.26	6.61	0.59 lb
GH-225-DHB	U	500 lbs	2.13	2.75	1.00	0.87	1.50	1.42	0.26	6.61	0.63 lb
GH-200-W	U	880 lbs	2.13	2.36	1.65	1.18	2.76	1.96	0.39	9.45	1.32 lbs
GH-204-GB	Open	1,400 lbs	1.77	3.15	2.24	2.00	3.27	2.80	0.37	10.6	2.60 lbs
GH-204-G	Open	1,400 lbs	2.00	3.00	2.76	1.18	3.54	1.89	0.33	10.55	2.69 lbs
GH-204-GBLH	U	1,400 lbs	2.79	5.00	2.24	2.00	3.27	2.80	0.37	12.44	2.78 lbs

UNIT: inches

## Toggle Clamps for Welding Applications



GH-10448



GH-25383



GH-36224



GH-204-G



GH-80325



# Good Hand™ Toggle Clamps



Toggle design allows instant lock & release of the workpiece.

## Push/Pull Straight Line Action



GH-36003

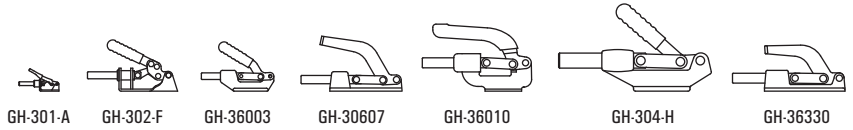
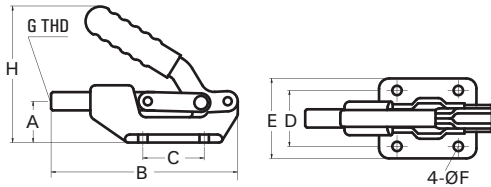

Part No.	Capacity	Plunger Stroke	A	B	C	D	E	ØF	G	H	Weight
GH-301-A	100 lbs	0.63	0.50	2.68	0.63	0.63	1.06	0.17	8-32	1.73	0.11 lb
GH-302-F	300 lbs	1.25	0.96	5.51	1.38	1.61	2.20	0.20	5/16-18	3.07	0.66 lb
GH-36003	600 lbs	1.25	0.97	4.69	1.44	1.34	1.97	0.26	5/16-18	3.23	0.78 lb
GH-30607	700 lbs	1.63	0.69	6.03	1.37	1.63	2.19	0.28	5/16-18	3.28	1.54 lbs
GH-36010	800 lbs	1.63	1.75	6.75	1.63	1.63	2.25	0.34	3/8-16	4.06	1.76 lbs
GH-304-H	1,500 lbs	2.36	1.75	9.38	2.00	2.00	2.81	0.34	1/2-13	6.76	3.26 lbs
GH-36330	2,500 lbs	2.00	0.81	7.00	1.37	1.63	2.25	0.34	3/8-16	2.83	2.06 lbs

UNIT: inches

## Latch Type Pull Action

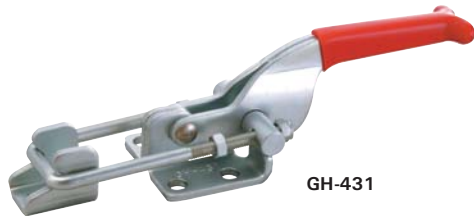

GH-431

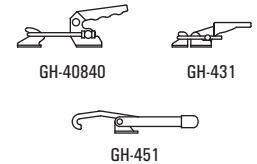
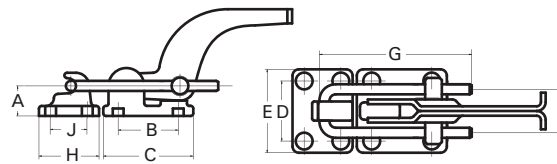

Part No.	Capacity	A	B	C	D	E	F	G	H	J	Weight
GH-40840	550 lbs	0.50	0.75	1.38	1.26	1.89	1.12	4.30	1.30	0.55	0.67 lb
GH-431	700 lbs	0.50	0.63	1.03	0.75	1.11	0.75	2.24	0.78	0.39	0.50 lb
GH-451*	375 lbs	1.44	0.75	1.50	1.37	1.94	0.31	8.31	2.00	1.50	0.59 lb

\*Adjustable single hook design. Optional latch plate GH-451-LP.

UNIT: inches

## Yoke Assemblies

Hold two workpieces with one stroke. The yokes have spring loaded, extra-wide spindles that provide strong holding power that adjusts to varying material thickness and sizes. Hold two workpieces or long pieces of metal.

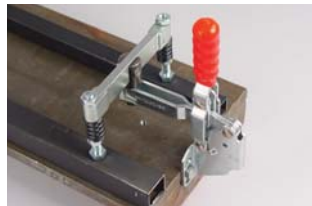

GH-YB-3145 paired with a vertical side-mount clamp (GH-12130-SM)

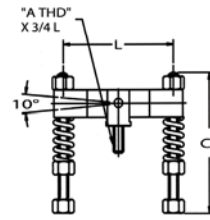

Spring Solid Height : 0.5  
Spring Free Height : 1"

Part No.	A	L	C1
GH-YB-3145	5/16-18	4.5	2.5
GH-YB-3160	5/16-18	6.0	2.5
GH-YB-3745	3/8-16	4.5	3.0
GH-YB-3760	3/8-16	6.0	3.0

UNIT: inches

Please call us at 800.989.5244 to request a comprehensive Good Hand™ Catalog.



GH-75027



GH-43160



GH-30509



GH-70310



GH-10247-A

## Replacement Parts and Accessories.

### U-Clamps Replaceable Parts

Replaceable Arm and Spindle Kits

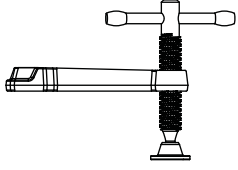

P/N	For U-Clamps Series
XER	UE Series
XFR	UF Series
XGR	UG Series
XMR2	UM Series (Equipped with H.D. Pad)
XMRP2	UM Series (Equipped with Standard Pad)
XPR	UP Series

### Individual Clamp Arms and Spindles

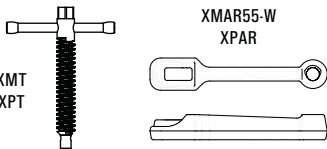

P/N	Description
XMT	Spindle for UM Series
XPT	Spindle for UP Series
XMAR55-W	Clamp Arm for UM Series
XPAR	Clamp Arm for UP Series

### Spring Stop Replacement Kit

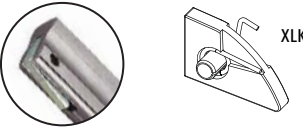

P/N	Description
XLK	For UE, UF, UG & UM series clamps.

### Pliers Replacement Parts

Spring & Adjustment Bolt for Pliers.

Spring - 4 per set  
PXS11  
PXS6

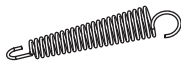

Adjustment Bolt  
PXB11  
PXB6



P/N	For Pliers
PXS11	11" Pliers
PXS6	6" & 8-1/2" Pliers
PXB11	11" Pliers
PXB6	6" & 8-1/2" Pliers

### Swivel / Pivot Pads (For Pliers)

Flat pads pivot at 150° and round pad swivels at 360°.

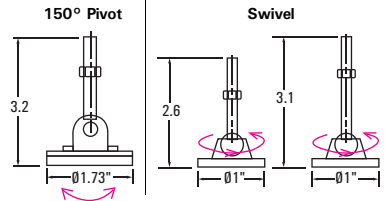

P/N	Thread	Length
854944 (Pivot) 854944M	3/8-16 M10	3.2" 81 mm
854940 (Swivel) 854940M	3/8-16 M10	2.6" 66 mm
854930 (Swivel) 854930M	5/16-18 M8	2.6" 66 mm
854935 (Swivel) 854935M	5/16-18 M8	3.1" 78 mm

### Crank Handles (For Pliers)

Optional or replacement handles for all Strong Hand Tools™ Pliers.

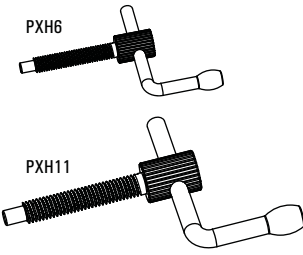

P/N	Thread	For Pliers
PXH11	3/8-16 M10	11" Pliers 280 mm
PXH6	5/16-18 M8	6", 8-1/2" Pliers 215 mm

### Big Hex Spindles (For Pliers)

Fixed head spindles for Multi-Purpose Pliers.

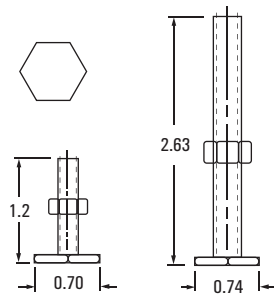

P/N	Thread	Length
854714 854714M	3/8-16 M10	2.6" 66 mm
854713 854713M	5/16-18 M8	1-1/5" 30 mm

### Heavy Duty Replaceable Pads

Replacement joints and pads for UM & UP clamps.

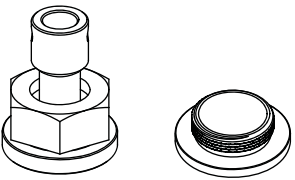

P/N	Description
XMJ	Joint & Pad Kit for UM & UP Clamps
XMA1	Replacement Pad only

### Fixed Glides (For Pliers)

With non-marring rubber pads.

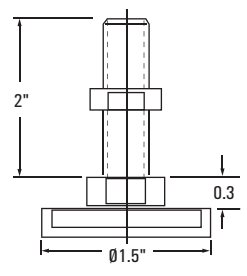

P/N	Thread	Length
854740P 854740PM	3/8-16 M10	2" 51 mm

### T-Strap Bolts (For Pliers)

For Step-Over applications.

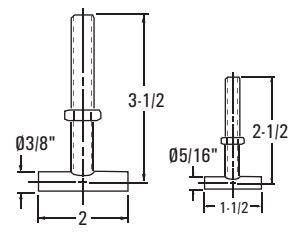

P/N	Thread	Length
840435 840435M	3/8-16 M10	3-1/2" 89 mm
840335 840335M	5/16-18 M8	2-1/2" 64 mm

# Accessories

## Accessories for Utility Clamps, Multi-Purpose Pliers and Expand-O Pliers.

### V-Pads (For U-Clamps & Pliers)

#### Standard V-Pads

Attach to pliers or clamps to hold round and angled workpieces.

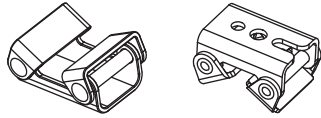

P/N	Tapped Hole	For Clamps	For Pliers
XDV	5/16-18 M8	UD Series	PG622 PG634
XFV	3/8-16 M10	UE, UF, UG Series	PG114 / PG134 PG204 / PGA20
XMV	3/8-16 M10	UM, UP Series	-
XDVS	5/16-18 M8	UD Series	PG622 PG634
XFVS	3/8-16 M10	UE, UF, UG Series	PG114 / PG134 PG204 / PGA20
XMVS	3/8-16 M10	UM, UP Series	-

STAINLESS STEEL

### Magnetic V-Pads

Rare earth magnetic V-Pads for holding round and angled pipes.

**2 magnets Version (Top only):**  
XDV2 / XFV2

**4 magnets version (Top & Bottom):**  
XDV4 / XFV4

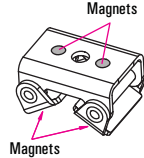
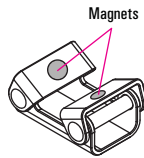

» XDV4 & XFV4 are table mount versions.

P/N	Tapped Hole	For Clamps	For Pliers
XDV2	5/16-18 M8	UD Series	PG622 / PG634
XDV4	5/16-18 M8	-	-
XFV2	3/8-16 M10	UE, UF, UG Series	PG114 / PG134 PG204 / PGA20
XFV4	3/8-16 M10	-	-

### 4-IN-1 Packages (For U-Clamps)

Convert all Utility Clamps into 4-IN-1 Clamps. Includes a V-pad, an Extender Block, and a screw.

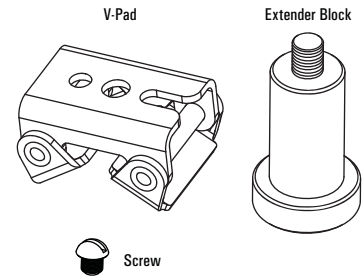

P/N	V-Pad / Extender Block
XDVB XDVBMB	XDV / XDB1 (For UD Models)
XFVB XFVBMB	XFV / XFB (For UE, UF, UG Models)
XMVB XMVBMB	XMV / XMB2 (For UM, UP Models)

### Top V-Pads (For U-Clamps)

Attach to the top of Utility Clamps equipped with **Standard Pads**.

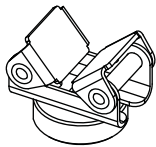

» Light Duty & Value Series

P/N	For U-Clamps Series
XDA2	UD Series
XFA2	UE, UF, UG Series
XMA2	UM, UP Series
XDA2S	UD Series
XFA2S	UE, UF, UG Series
XMA2S	UM, UP Series

STAINLESS STEEL

#### Screw-On V-Pads

Attach to the top of Utility Clamps equipped with **Heavy Duty Pads**.

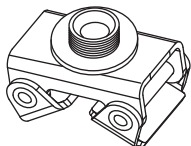

» For Regular and Heavy Duty Series

P/N	For U-Clamps Series
XMA	UM, UP Series
XMAS	UM, UP Series

S.S.

### Extender Blocks (For U-Clamps)

Attach to U-Clamps for Step-Over and Spreading applications.

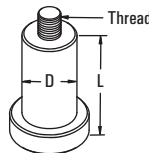

P/N	Thread	D	L	For Clamps
XDB1 XDB1M	5/16-18 M8	3/4" 16 mm	1" 25 mm	UD Series
XFB XFBM	3/8-16 M10	1-3/16" 30 mm	2" 51 mm	UE, UF, UG Series
XMB2 XMB2M	3/8-16 M10	1-3/16" 30 mm	2" 51 mm	UM, UP Series

### Sidekicks (For U-Clamps)

Mount onto U-Clamps for 2-axis horizontal clamping.

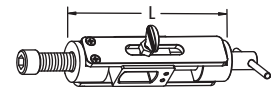

P/N	L	Stroke	For Clamps
XDS XDSDM	3-1/8" 79 mm	1" 25 mm	UD Series
XFS XFSM	4-3/8" 111 mm	1-3/8" 35 mm	UF Series
XGS XGSM	4-3/8" 111 mm	1-3/8" 35 mm	UG Series
XMS XMSM	4-3/8" 111 mm	1-3/8" 35 mm	UM Series

### Bench Rests (For U-Clamps)

Supports U-Clamp in Standing Position.

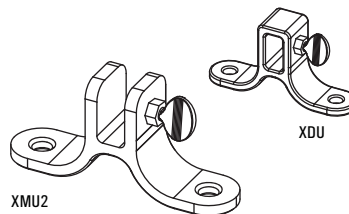

P/N	For U-Clamps Series
XDU	UD Series
XMU2	UM Series

### Pipe Adaptors (For Expand-O Pliers)

Attach to Expand-O Pliers for wide spreading jobs and U-clamps for Step-Over applications.

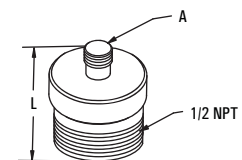

P/N	L	A	Expand-O	For Clamps
XDJ XDJM	1-1/16" 27 mm	5/16-18 M8	PE6, PE62 PE6M, PE62M	UD Series
XFJ XFJM	1-5/32" 29 mm	3/8-16 M10	PE10 PE10M	UE, UF, UG UM, UP





# BuildPro™ Welding Tables

Faster Fixturing. Consistent Results. Greater Productivity.

The affordable, professional BuildPro™ Welding Tables are setting a new standard in price and performance.

The BuildPro's modular design gives you the flexibility to adapt to each new project easily. You'll work more safely, and more efficiently, so you can increase both your productivity, and the quality of your work.

Plates can be reconfigured to extend the width of the table for larger projects.

Precision, ground steel plates, with CNC machined 5/8 holes in a 2" grid pattern for locating, positioning and holding your fixture with the BuildPro™ clamps and components.

## BuildPro™ Clamps

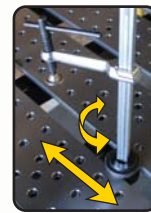

### 360° Clamps

- Insert the clamp into the T-slot and slide along the entire surface for positioning at any point.
- Clamp swivels 360°.



### Inserta-Clamps

- Fit into the 5/8 grid holes for fast and easy clamping.
- Clamp swivels 360°.

1-3/4" T-slot spacing designed for optimum flexibility.

Heavy Duty Leveling Feet ensure proper leveling of the table on uneven surfaces.

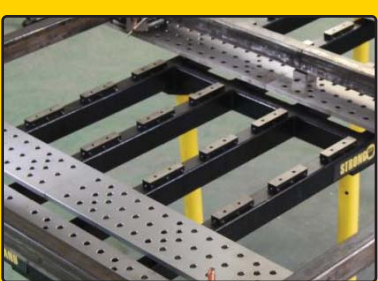

Heavy Duty 4 Beam support base provides a 2 ton load capacity.

## The table you'll rely on everyday...

Save time and money by holding, positioning, and locating quickly and easily with a wide variety of BuildPro™ Clamps and Components. Please visit our website at [www.stronghandtools.com](http://www.stronghandtools.com) for more information or call us at Toll Free 1-800-989-5244 to request the complete BuildPro™ Welding Table Catalog.

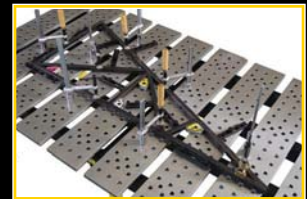

## Standard Machine Parts and Tooling Components

Our Valtra® catalog features a wide range of Clamps, Machine Parts, Tooling Components, and Fasteners. Call to request a copy of the full line catalog. Modifications to standard parts and custom requests welcome.

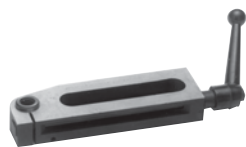

Bedding Supports



Cam Action Clamps



Forged Adjusta-Clamps



Adjustable Handles



Center Cam Clamps



Rotary T-Slot Nuts



Handwheels



Spring Stops



Handknobs



Cap Screw Hook Clamps



Speed Ball Handles



Crank Handles



Clamping Levers



Lifting Eyebolts



Leveling Pads



Heavy Duty Fixed Glides



T-Slot Bolts



Rotary T-Slot Bolts



Plain Eyebolts



T-Strap Bolts



**Better Tools. Better Price.®**

**Visit us online at  
[www.stronghandtools.com](http://www.stronghandtools.com)**

**Authorized Distributor**

**Customer Service**

Toll Free : 800.989.5244

Tel : 562.949.8625

Fax : 562.949.4875

[sales@stronghandtools.com](mailto:sales@stronghandtools.com)

**Address**

7141 Paramount Blvd.,  
Pico Rivera, CA 90660,  
U.S.A.

© Copyright 2010.  
All Rights Reserved.